



TETRA PAK® UPGRADES

Extended value from your equipment



We maximize client operational life cycle performance.

Tetra Pak® Services cover every aspect of your food production, from daily routines to business insights. Our tailored service solutions improve performance, optimise costs and ensure food safety throughout the lifecycle of your operation.

With Tetra Pak as your partner, you get the people, portfolio and presence to achieve your performance goals.





TETRA PAK® UPGRADES

A complete portfolio of services for all your operational needs

Tetra Pak® Upgrades are retrofittable kits, pre-defined products or customised solutions that further improve the performance of your installed equipment.

We will support you in

- 1 Understanding the effect of changes from production demands
- 2 Enhancing upgrade solutions
- 3 Minimizing installation time and downtime
- 4 Maintenance across entire equipment life cycle

We provide services for a diverse range of industries to help you improve



Sustainability



Productivity & Efficiency



Food Safety & Quality



New Requirement for your Line



TABLE OF CONTENTS

PROCESSING

Sustainability
Productivity & Efficiency
Food Safety & Quality
New Requirement for your Line

5

AUTOMATION

Sustainability
Productivity & Efficiency

25

PACKAGING

Sustainability
Productivity & Efficiency
Food Safety & Quality
New Requirement for your Line

14

ICE CREAM

Productivity & Efficiency
Food Safety & Quality
New Requirement for your Line

30

01 PROCESSING



We focus primarily on 5 different food applications, namely dairy, beverages, prepared food, ice cream and cheese. All our applications and technology have been developed primarily for processing these food categories.

Sustainability

Energy Management for Heat Exchangers

Productivity & Efficiency

Improved Running Time	IntelliCIP™ 2.0	Machine Control Equipment – Homogenizer
Automatic CIP & Refill of Homogenizer Dampers	Remote Pressure Setting & Reading – Homogenizer	Rebuilding Kit Basic to Aseptic Homogenizer

Food Safety & Quality

Differential Pressure Supervision

New Requirement for your Line

Production Capability Updates – New Capacity	Production Capability Updates – New Application	Aseptic Line Flexibility
--	---	--------------------------

PROCESSING UPGRADES PRODUCT PORTFOLIO

Plant Level Upgrades

- Water recovery to rinse-water tank
- Product recovery systems
- Energy recovery systems
- CIP Station Upgrades
- Valve cluster & piping upgrades
- Key component upgrades
(Separator, Homogenizer, Pasteuriser)

Tetra Alcip®

- New Object Addition
- Capacity Expansion
- Replacement of Control Panel



Tetra Therm® Aseptic VTIS

- Aseptic Energy Hibernation
- Differential pressure measuring
- Conductivity switch
- New Control Panel
- E-Series HMI Upgrade
- Mix phase reduction
- Increased capacity & add new product

Tetra Alex Homogenizer

- Homogenizing Device, HD 100 & Energy IQ
- Eco Cooling Homogenizer
- Cross Head Seal Mushroom Valves
- Turnable Disk (TD)
- Valves Solid Ceramic Pistons
- Machine Control
- Remote reading 1st and 2nd stage

Tetra Alsafe®

- Low Fouling End Valve Cluster
- Aseptic Filling Flexibility, Single ISB Connection
- Aseptic Filling Flexibility, Double ISB Connection
- New Control Panel
- E-Series HMI Upgrade
- Full Aseptic Line Flexibility



Energy Management for Heat Exchangers

UG Name	Energy Management for Heat Exchangers
System/Machine affected	Tetra Pak® Plate Heat Exchanger Tetra Pak® Tubular Heat Exchanger
Value Category	Operational Efficiency & Cost
Implementation Time	~5 days



What does it do:

Energy management is an analysis and consulting service with the purpose of improving our customers' production economy.

For many heat exchangers, increasing the heat recovery level is a hidden source of substantial yearly cost savings.

We analyze the customer's heat exchangers and propose upgrades to reduce the customer's operational cost. The focus is on increasing the heat recovery level and reducing energy consumption.

Three possible upgrades can be suggested:

- Re-optimization (PHE & THE)
- Re-build (PHE & THE)
- Insulation (THE)

Benefits:

- Reduces operating costs by improved energy efficiency
- Minimizes environmental impact
- Improves occupational health and safety by decreasing heat loss



Improved Running Time

UG Name	Improved Running Time
System/Machine affected	Tetra Pak® Indirect UHT (& Tetra Therm Aseptic Flex)
Value Category	Operational Cost & Environment
Implementation Time	Depends on level of upgrade

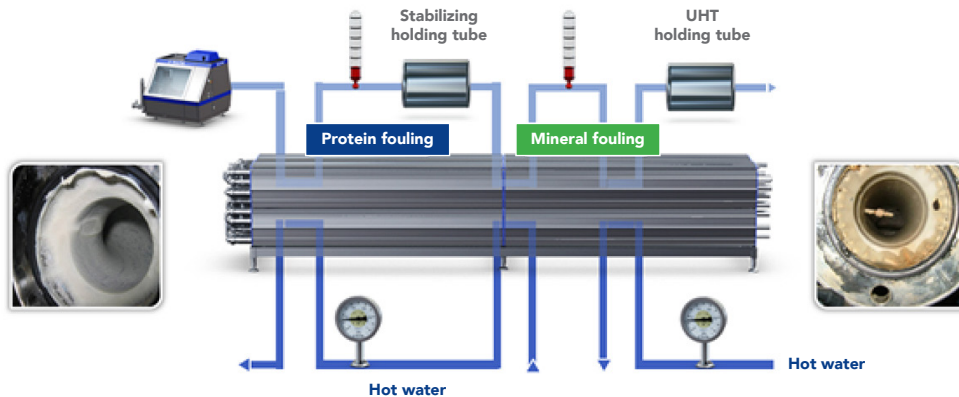

What does it do:

Improved running time is often an effective way to reduce operational cost. Depending on processed product mix and if the need for flexibility in production is low, extending production time between CIP/AIC is a good way to reduce operational cost. There are different options on how production time can be improved, from simply adding a protein stabilization holding cell without temperature control to adding heating surface and rearranging the tubular heat exchanger.

Improved running time is a concept which contains different options:

- Protein stabilization holding cell 60 – 120 sec (if not existing)
- Correction cooler/heater
- Additional heating surface
- Process & automation engineering

Benefits:

- Improved running time is a concept which contains different options:
- Reduced product losses
- Reduced operational cost and environmental impact

IntelliCIP™ 2.0

UG Name	IntelliCIP™ 2.0
System/Machine affected	Tetra Pak® Indirect UHT (Tetra Therm Aseptic Flex)
Value Category	Operational Efficiency & Environment
Implementation Time	~5 days

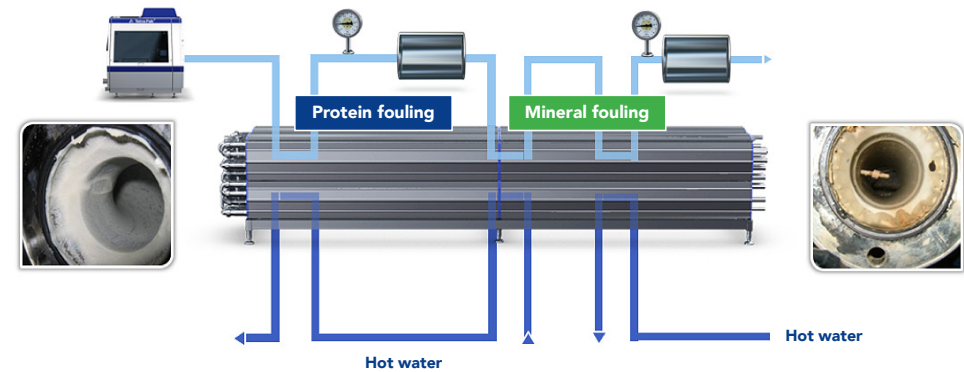

What does it do:

IntelliCIP™ 2.0, including CIP sensors for monitoring of CIP result enables the customer to follow how the fouling is removed (presented as a graphs in the HMI) from the surfaces inside the plant while cleaning is in progress. This gives the opportunity to optimize the cleaning procedure and only cleaning according to need.

- Demand-adapted CIP
 - type of product
 - length of production cycle
 - amount of fouling (ΔT and ΔP)

IntelliCIP™ 2.0 upgrade is composed by:

- Pressure sensors
- Update of the existing software programs, PLC and local HMI
- Update of the technical, operator and electrical documentation

Benefits:

- Improving the production efficiency, environmental impact & increasing uptime
 - Safeguard CIP result and maximize uptime
 - Accurate dosing cuts detergent consumption
- Optimizing energy consumption in different phases due to shorten CIP time based on level of fouling

Machine Control Equipment – Homogenizer

UG Name	Machine Control Upgrade
System/Machine affected	Tetra Pak® Homogenizer
Value Category	Operational Efficiency & Protecting the Equipment
Implementation Time	2-4 days

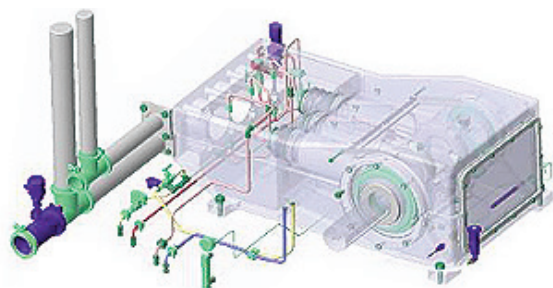

Wet End

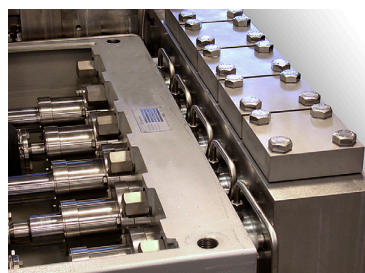

What does it do:

This upgrade consist of:

- 1 Inlet pressure transmitter
- 2 Crank case thermostatic valve
- 3 Cooling water flow guard
- 4 Crank case oil level transmitter
- 5 Crank case oil temperature

Too low inlet pressure can create unwanted cavitation in the machine. Tetra Pak recommendation is 3-10 bar depending on viscosity. Higher the viscosity, higher the inlet pressure required. With the inlet pressure transmitter, the machine can be set up to shut off the hydraulic pressure if inlet pressure is found to be too low, in order to protect the machine.

With this upgrade the cooling water to the crankcase will be controlled. Only when the oil has reached its designated operating temperature will the cooling water start to flow. This will minimize the cooling water consumption and improve the lubrication in the crankcase. The oil level in the crankcase will also be controlled, enabling detection of leakage in or out of the crankcase.

Benefits:

- Protection of machine from unwanted cavitation
- Water saving
- Short payback time

Automatic CIP and Refill of Homogenizer Dampers

UG Name	Automatic CIP and Refill of Homogenizer Dampers
System/Machine affected	Tetra Pak® Pasteurizer, Tetra Pak® Indirect UHT and Tetra Pak® Direct UHT (Tetra Therm Family)
Value Category	Occupational Health & Safety and Operational Efficiency
Implementation Time	5-10 days

Non-aseptic version

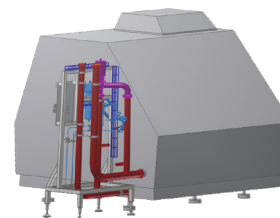

Aseptic version

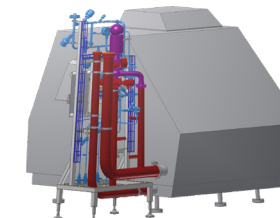

What does it do:

This Upgrade allows for automatic filling of the homogenizer dampers with air during production, which enables good running conditions for the homogenizer. Automatic cleaning of the dampers means no manual dismantling and cleaning is needed. The feature is available in aseptic and non-aseptic version.

The automatic CIP and refill of homogenizer dampers upgrade consists of:

- A skid mounted module with inlet and outlet damper, air blow valve, level transmitter, bypass valve, back pressure valve
- Update of the existing software programs, PLC and local HMI
- Update of the technical, operator and electrical documentation

Benefits:

- Homogenizer dampers absorb pressure variation and shocks before and after the homogenizer. Automatic air refill maintains the air cushion in the homogenizer damper to ensure smooth operation. Without the air cushion, vibration and cavitation would occur and shorten the running time. Fully automated CIP is included - increasing operator safety, improving hygiene and further optimizing the production cycle.
- Improved running conditions for the homogenizer thanks to automatic air filling of the dampers during production and longer running hours
 - Automatic CIP, no manual cleaning is needed
 - Increased Human Safety

Remote Pressure Setting & Reading – Homogenizer

UG Name	Remote Pressure Setting & Reading – Homogenizer
System/Machine affected	Tetra Pak® Homogenizer
Value Category	Operational Efficiency
Implementation Time	1-3 days



What does it do:

This upgrade will equip the homogenizer with the feature to set the pressure remotely. The upgrade consists of two options : remote continuous setting and remote continuous setting with remote reading of pressure in first stage. The customer benefit is mainly when more than one recipe is used. With the feature of being able to set the pressure remotely the production can be more automated.

Remote reading of both 1st and 2nd stage pressure is possible through a separate Upgrade Kit. The main benefit is for customers who have a demand to have a specific pressure ratio between 1st and 2nd stage pressure.

Benefits:

- Improve flexibility
- Less manual intervention during project change over
- Faster recovery & support in case of breakdown

Rebuilding Kit Basic to Aseptic Homogenizer

UG Name	Remote Pressure Setting & Reading – Homogenizer
System/Machine affected	Tetra Pak® Pasteurizer, Tetra Pak® Indirect UHT and Tetra Pak® Direct UHT (Tetra Therm Family)
Value Category	Occupational Health & Safety Operational Efficiency
Implementation Time	5-10 days

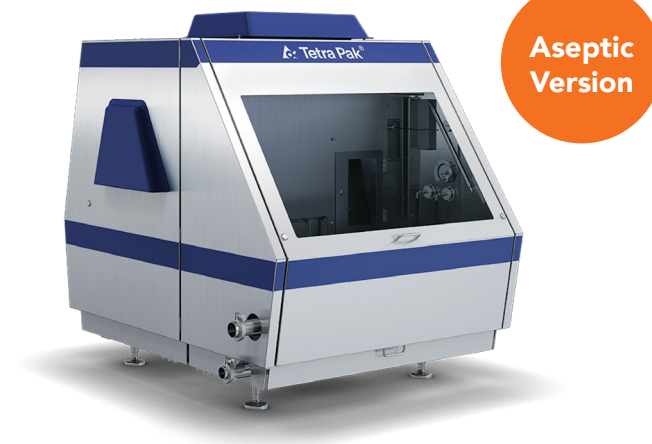

What does it do:

The upgrade consist of:

- New cooling circuit with condenser.
- Automatic regulation of condensate temperature.
- Chromium plated pistons and aseptic seals. Other pistons available through quote.
- Aseptic dampers.
- The upgrade is available for existing and previous machine models. Exception is model Ms05 that is aseptic by default and M2 that is not available in aseptic version.

Benefits:

By upgrading existing machine to aseptic machine the customer does not have to invest in new equipment.

Differential Pressure Supervision

UG Name	Differential Pressure Supervision
System/Machine affected	Tetra Pak Indirect UHT Units Tetra Pak Direct UHT Units Tetra Pak Pasteurizers
Value Category	Food Safety
Implementation Time	4-6 days

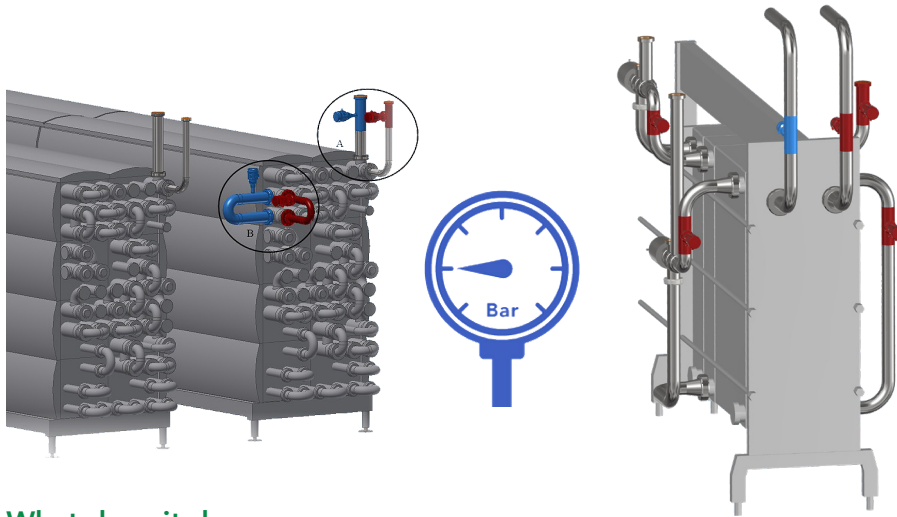

What does it do:

Differential Pressure Supervision will, with added pressure transmitter, allow for measurement of the differential pressure between the product and water side, or in case of product to product regeneration, between treated and untreated product.

A number of options are available, depending on the solution and the Processing Unit. By ensuring a higher pressure on the treated side the food safety can be maintained in case of leakage as well.

Benefits:

- Improved food safety
- Less risk of product contamination
- Follow legal and/or retailer requirements
- Protect and maintain trademark value
- Reduce risk of product failures being distributed to consumers



Production Capability Upgrades – New Capacity

UG Name	Production Capability Upgrades – New Capacity
System/Machine affected	Liquid Food Processing Units such as, Tetra Pak® Heating Units & Key Components
Value Category	Production Capability
Implementation Time	Depends on level of upgrade

**Meeting
Volume
Demand**

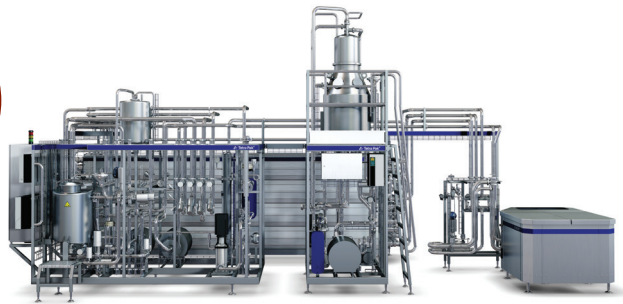

What does it do:

By re-designing the Tetra Pak Processing units and/or Key Components the capacity can be changed to customer's new requirements. Thus, enable you to tailor make your production schedule, making it easier to introduce new filling machines.

The configuration of the existing process design might need to be modified in order to get optimal production performance at the specified capacity. Depending on the capacity change, heat exchanger, holding tube, valves and pumps needs to be modified or changed to correspond to the changed capacity.

Production Capability Upgrades – New Capacity is composed by:

- Process Upgrade
- Automation Upgrade
- Update of the existing software programs, PLC and local HMI
- Update of the technical, operator and electrical documentation

Benefits:

- Increased Flexibility
- Improved Utilization
- Short Payback Time

Production Capability Upgrades – New Application

UG Name	Production Capability Upgrades – New Application
System/Machine affected	Liquid Food Processing Units such as, Tetra Pak® Heating Units & Key Components
Value Category	Production Capability
Implementation Time	Depends on level of upgrade



Dairy



Beverage



Prepared Food

What does it do:

Adding a new product or changing the product specification increases the product lines performance and optimizes the flexibility.

Various changes have to be made to the existing Tetra Pak Processing units and/or Key Components depending on the demand of the new product. By this upgrade the time to introduce a new product in the market is short, which improves business competitiveness.

Production Capability Upgrades – New Application is composed by:

- Process Upgrade
- Automation Upgrade
- Update of the existing software programs, PLC and local HMI
- Update of the technical, operator and electrical documentation

Benefits:

- Increased Flexibility
- Improved Utilization
- Short Payback Time

Aseptic Line Flexibility

UG Name	Aseptic Line Flexibility
System/Machine affected	Tetra Pak® Aseptic tank (Tetra Alsafe)
Value Category	Operational Efficiency & Cost and Environment
Implementation Time	Depends on level of upgrade

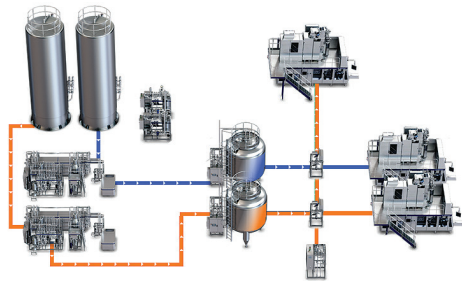

What does it do:

Aseptic Line Flexibility – the line designed to meet the highest demands on flexibility. It enables UHT treatment with multiple lines feeding buffer tanks, based on an ALF (aseptic line flexibility) valve cluster that offers full flexibility for feeding to different tanks and filling machines under aseptic conditions. The ALF line concept does not require a production stop for CIP before changing filling machines.

The valve cluster upgrade consists of:

- Necessary components for the aseptic filling line valve cluster.
 - The number of cross connections varies depending on the production layout.
 - Main Air Valve Cluster (up to 20 connections)
 - Connection Valve Cluster
 - Line End Valve Cluster
- Separate control system including soft and hardware
- Assembly drawings
- Technical and electrical documentation

Benefits:

- Improving the operational efficiency, environmental impact & increasing uptime
- Aseptic line flexibility will increase the production efficiency due minimizing stops for CIP due to batch size, change of recipes etc.
- Possibility to maximize uptime of filling machines



02 PACKAGING

Consumer trends around the world indicate a demand for more advanced food and beverages and our customers are actively staying ahead launching new products and product variations to meet market demand. As a result, the range and complexity of products filled in Tetra Pak packages has increased immensely over the last few years. To meet these evolving technology demands, our equipment will need to meet different and new requirements to secure performance when packing more complex products.



Sustainability

Nordson ProBlue 4
TSA 22HS



Productivity & Efficiency

MaPS

Headspace Unit

OFU – Oil Filtering
Unit TP/A3

Jaw System
Cutting Knife

Replacement Flexbox VI

U/P Transducer

EcoDot
CBP32 – TCBP70

02 PACKAGING



Food Safety & Quality

New Aseptic
Product Valve NAPV

Lower Filling
Pipe Cleaner

Upper Filling Pipe
for A3/CF

Upper Filling Pipe
for TBA/19



New Requirement for your Line

Production
Capability Upgrades
– A3/S Up Speed

PACKAGING UPGRADES PRODUCT PORTFOLIO

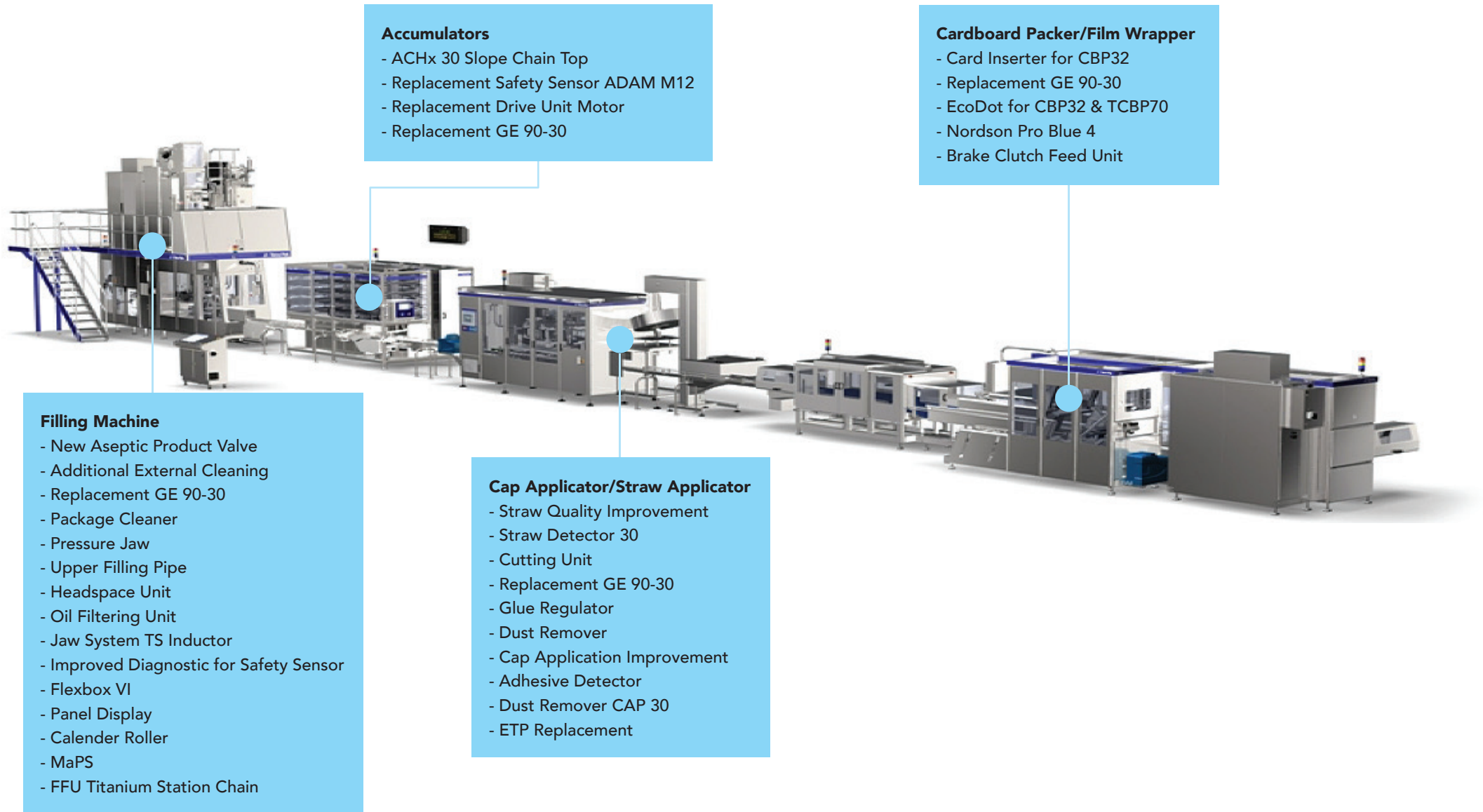



Nordson ProBlue 4 TSA 22HS

UG Name	Nordson Pro Blue 4
System/Machine affected	TSA 22 HS -0100, -0200
Value Category	Capability
Implementation Time	1 day

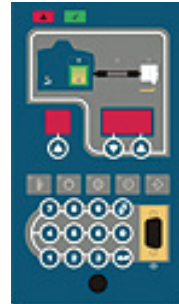

What does it do:

The kit introduces a Nordson Pro Blue 4 unit replacing the old Hot Melt Unit no longer in production.

Benefits:

- Improve the hot melt application by using a modern & a better performing technology
- Minimize unplanned downtime impact due to an obsolescence unit replacement by planning a proactive installation of this kit
- Simplify daily operation and reduce the maintenance activities by a non-stick coated tank, a more easy access to the unit, and an intuitive graphic interface, with system status and temperature monitoring (tank, hose, gun)



MaPS

UG Name	Magnetic Positioning System (MaPS)
System/Machine affected	TP A3/S -0200, -0300, -0400
Value Category	Operational Efficiency
Implementation Time	5-7 days

Tetra Pak A3/Speed for TBA 125 S

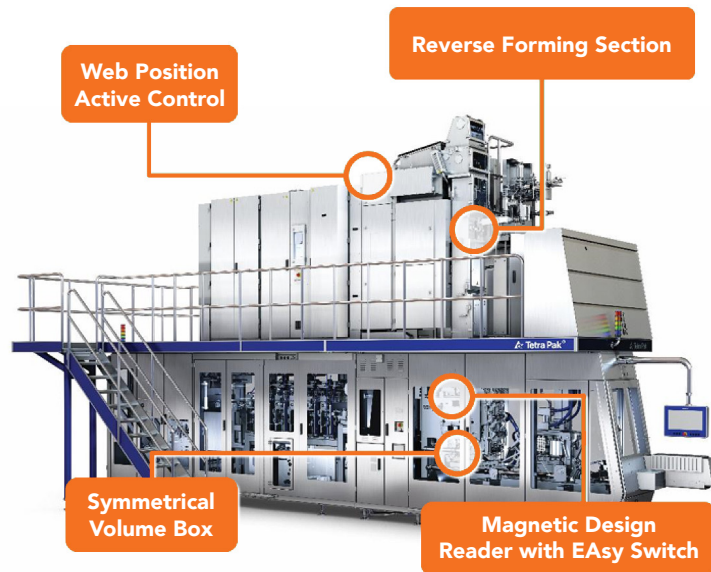

What does it do:

The kit combines magnetic inks (static marks) printed into the packaging material with magnetic readers located inside the Filling Machines.

Benefits:

Reduce Customer Operational Cost by improving:

- Filling Accuracy
- MME, MTBF (Capacity increase)
- Packaging Material waste
- Product waste
- Operational activities (reduce number of operator tasks)

Headspace Unit

UG Name	Headspace Unit
System/Machine affected	TBA/19 -0300, -0500 Tetra Pak® A3/Flex -0200, -0300, -0400, -0600 Tetra Pak® A3/Speed -0200, -0300, -0400, -0500
Value Category	Operational Efficiency
Implementation Time	4-5 days

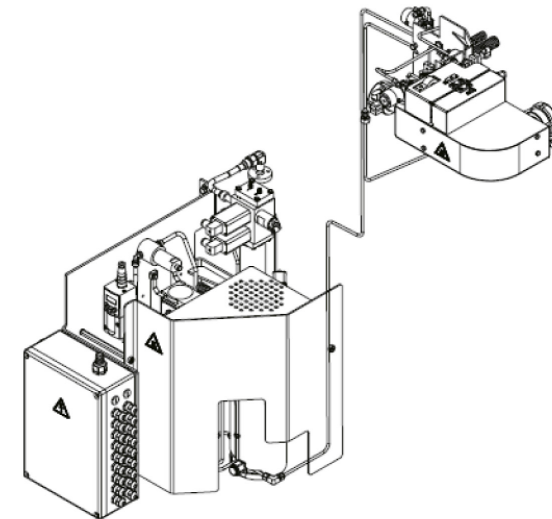

What does it do:

- This Optional Kit provides the opportunity of creating headspace inside each package according to the product being filled.
- Headspace unit is a system able to blow a controlled amount of sterile inert gas, air or nitrogen (depending on the product being filled) directly into the product line.
- The amount of injected gas can be in the range of 2% - 10%.
- All the parts of the HI that are intended to be in contact with the product are sterilised and cleaned during the Cleaning-In-Place (CIP).

Benefits:

- Fill packages by weight rather than by volume (e.g. tomato)
- Fill packages with products that need to be shaken
- Achieve better pouring properties for certain products

OFU – Oil Filtering Unit TP/A3

UG Name	OFU
System/Machine affected	TP A3/F -0100, -0150, -0160, -0200, -0300, -0400 TP A3/CF -0100, -0200, -0300, -0400
Value Category	Efficiency
Implementation Time	1-2 days



What does it do:

The solution consists of a coalescence filter for hydraulic system oil that removes:

- Insoluble particles
- Oil degradation products
- Water

Benefits:

Decreases customer system cost extending oil lifetime from 2000h to 4000h and reducing the risk of filling machine breakdown due to oil degradation.

Jaw System Cutting Knife

UG Name	Jaw System Cutting Knife
System/Machine affected	Tetra Pak A3/F -0100, -0150, -0160 Tetra Pak A3/F -0200, -0300, -0400, -0600 Tetra Pak A3/CF -0100, -0200, -0300 Tetra Pak A3/S -0100, -0200, -0300, -0400, -0500 Tetra Pak TBA22 -0500
Value Category	Operational Efficiency and Food Safety
Implementation Time	4~6 hours



What does it do:

The kit introduces new knives in a more durable material (Stellite 6K chromium-cobalt alloy) with outstanding property of corrosion resistance and hardness.

Benefits:

Reduce downtime by improving component life time when packing complex and very complex products.

Additional Benefits:

- Reduce stops (in FFU) due to a better output quality
- Stable cutting quality

Replacement Flexbox VI

UG Name	Replacement Flexbox VI
System/Machine affected	Prio1: A3/Flex 0100 (*) TBA/8-1000 Prio2: TB/19, TBA/8-1100, TBA/8-1200, TBA/19, TBA/21, TBA/22, C3/Flex, A1
Value Category	Extended Life Cycle
Implementation Time	1-3 days

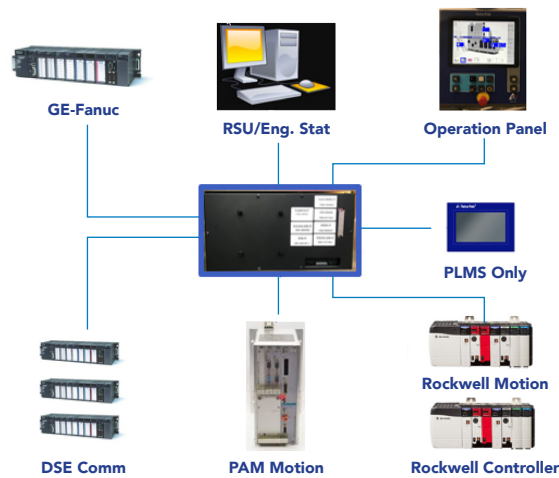

What does it do:

Industrial PC complete with panel (4:3) of 3 dimension:(8", 12", 15") depending on IPC. All IPC interfaces in scope granted including operator/PLMS panel replacement.

Benefits:

Address the obsolescence of the TPMC and extend the lifetime of the equipment.



U/P Transducer

UG Name	U/P Transducer
System/Machine affected	Tetra Pak A3/Compact Flex -0100, -0200, -0300
Value Category	Operational Efficiency
Implementation Time	1 day



Existing Solution:
Norgren VP50



New Solution:
Sentronic 833

What does it do:

This Tetra Pak® Upgrade Kit is composed by the new Sentronic transducer, the adapter plate and the cable to be connected in the Valve Panel.

Benefits:

Improvements introduced with the new transducer:

- More robust vs current application
 - Less sensitive to product line disturbances
 - Less sensitive to compressed air quality conditions
- Faster response time
- No need of manual settings from the operator
- Reduces risk of events related to product instability

EcoDot CBP32 – TCBP70

UG Name	EcoDot
System/Machine affected	CBP32 -0200 to -0700 TCBP70 1100 to 1200
Value Category	Operational Efficiency
Implementation Time	8 hours

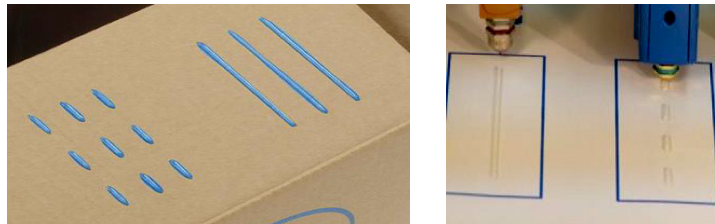

What does it do:

The kit is composed of new hotmelt guns and gun holder and it applies short, intermittent beads in place of long continuous beads of hot melt.

- For CB32, an EcoDot icon is introduced in the HMI
- For TCBP70, a pattern generator enables the EcoDot function

Benefits:

The saving of hotmelt consumption is from 15% to 30% depending on the type of distribution unit.

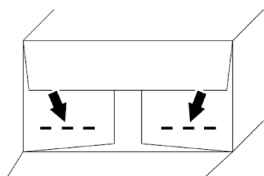

Intermittent adhesive dots

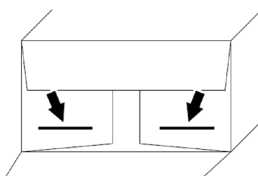

Continuous adhesive dots

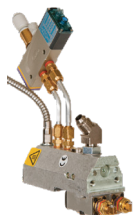

New Aseptic Product Valve NAPV

UG Name	New Aseptic Product Valve NAPV
System/Machine affected	Tetra Pak A3/CF, A3/F, A3/S
Value Category	Food Safety
Implementation Time	3-5 days

New design to improve the current AP valve functionality

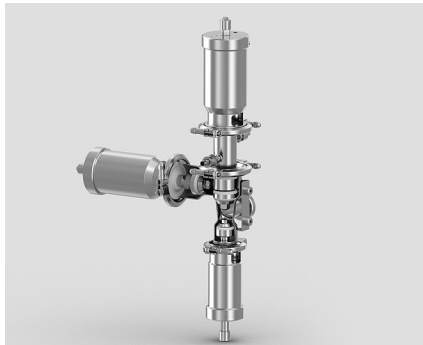

Current Aseptic Product Valve

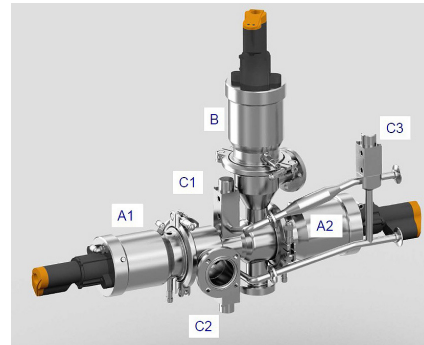

New Aseptic Product Valve

What does it do:

Replace the current Aseptic Product Valve (ABC Valve) with the new Aseptic Product Valve. This kit includes also pipe connections from-to the new valve with steam system, sterile air system, filling and cleaning system.

The new design aims to improve current AP-valve functionality.

Benefits:

- Reduction of operational downtime by A-valve seat automatic cleaning during CIP – no need of weekly manual cleaning
- Lower operating temperature (minimizing the product burnt) by having the sterile condensate steam barrier (as option) instead of sterile steam barrier
- More accurate and reliable coupling by using new mechanical connections (DIN 11864) instead of clamps – the tightening does not rely on the operator
- Easier operator task during cleaning in place enabled by a new position of swing bend/ flow switch (A3S – A3CF)

Lower Filling Pipe Cleaner

UG Name	Lower Filling Pipe Cleaner
System/Machine affected	A3/CF -0200, -0300 (with ICU only)
Value Category	Food Safety
Implementation Time	3~10 hours

UG Name	Lower Filling Pipe Cleaner
System/Machine affected	A3/F -0150 from T-Order 21211/00049 * A3/F -0160, -0200 * A3/Flex 0300, 0400 (released in 2014)
Value Category	Food Safety
Implementation Time	1~6 hours

What does it do:

Kit is designed to integrate the cleaning of the lower filling pipe, floater, and counter pressure flange into the integrated cleaning system.

Benefits:

- Increasing the hygienic performance with automatic cleaning of the lower filling pipe and the accessories.
- Reduce operator cost by saving ~30 minutes of operator working time per cleaning cycle

*only with ICU

- ▶ Introduced as standard from serial number: 21218/00245 (A3F 0400)



Upper Filling Pipe for A3/CF

UG Name	Upper Filling Pipe
System/Machine affected	Tetra Pak® A3/CF -0100, -0200, -0300, -0400 (*)
Value Category	Food Safety and Operational Efficiency
Implementation Time	2 days

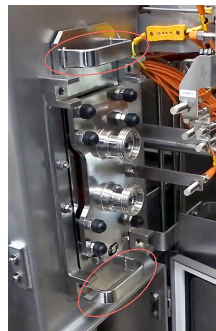

Existing Solution

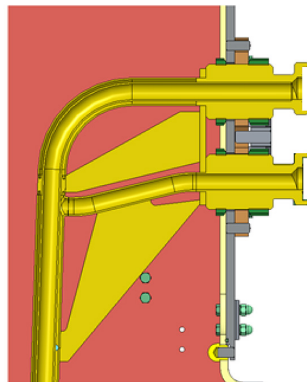

New Solution

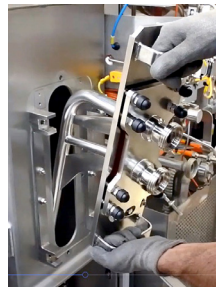
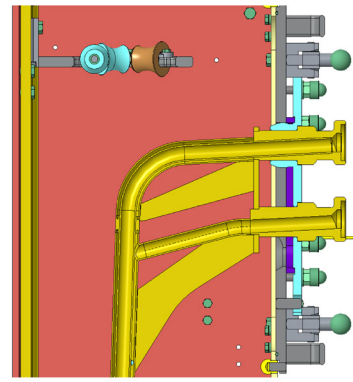

What does it do:

This Tetra Pak® Upgrades kit is composed by a new re-designed Upper Filling Pipe with a reinforced locking system to aseptic chamber.

Benefits:

Reduced Customer Operational Cost by:

- Decreasing operator manpower to align the position of the Upper Filling Pipe after CIP
- Decreasing filling machine downtime
- Reducing risks of Longitudinal Sealing problems/Package integrity/Package forming

Upper Filling Pipe for TBA/19

UG Name	Upper Filling Pipe
System/Machine affected	Tetra Pak® TBA/19 -0100 to -0500
Value Category	Food Safety and Operational Efficiency
Implementation Time	2 days

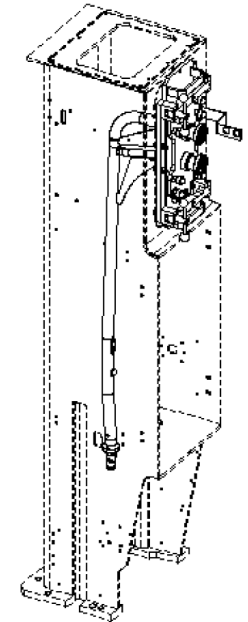
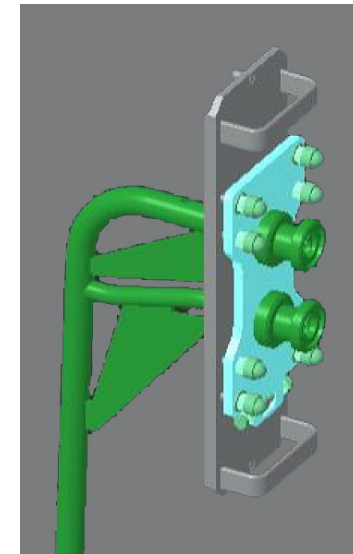
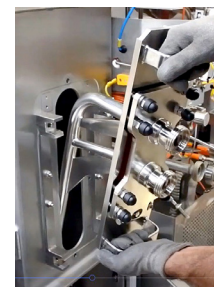
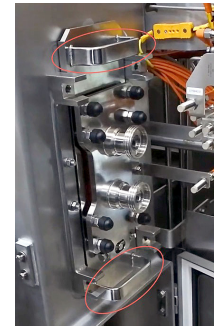

What does it do:

This Tetra Pak® Upgrades kit is composed by a new re-designed Upper Filling Pipe with a reinforced locking system to aseptic chamber.

Benefits:

Reduced Customer Operational Cost by:

- Decreasing operator manpower to align the position of Upper Filling Pipe after CIP and/ or weekly care
- Decreasing filling machine downtime
- Reducing risks of Longitudinal Sealing problems/Package integrity/Package forming

Production Capability Upgrades – A3/S Up Speed

UG Name	Machine Up-Speed
System/Machine affected	A3/S (Depends on Product & Packet Size)
Value Category	Production Capability
Implementation Time	Depends on level of upgrade



What does it do:

By re-designing the Tetra Pak machine, the capacity can be changed to customer's new requirements.

The configuration of the existing process design might need to be modified in order to get optimal production performance at the specified capacity. Depending on the capacity change, some parts need to be modified or changed to correspond to the changed capacity.

Installing the kit increases the nominal capacity of the filling machine from 24,000 packs/hour to 26,000 packs/hour (depending on product & machine type).

Benefits:

- Increased Flexibility
- Improved Utilization
- Short Payback Time
- Match market demand with a limited investment



03 AUTOMATION

Food production today is complex. It requires detailed control of plant operations - from the reception and processing of raw materials to the packaging and distribution of finished products. The greater your control, the more value you can squeeze out of your production.

We bring you over 40 years of experience in providing automation and information solutions tailored to the needs of the food industry – your needs – and have embedded that intelligence in our equipment and production solutions. This ensures you total control of plant operations, and the benefits that brings: enhanced and guaranteed performance, consistent product quality, uncompromising food safety and reduced environmental impact.



Sustainability

Tetra Pak® Plant Master
Software Upgrades
– Production Control



Productivity & Efficiency

New Control System
– Separator

New Control System
– Tetra Therm, Alsafe
& ALCIP

SCADA &
Report Generation

AUTOMATION PRODUCT PORTFOLIO

Processing Units

- Replacement HMI (Beijer, Proface, etc)
- Replacement PLC (ABB->Siemens, Rockwell)
- New Control Panel (Latest Platform)
- Cheese Vat Coagulation Sensor

Packaging

- Tetra Pak® Line Controller
- Tetra Pak® Line Gateway (LiGa)

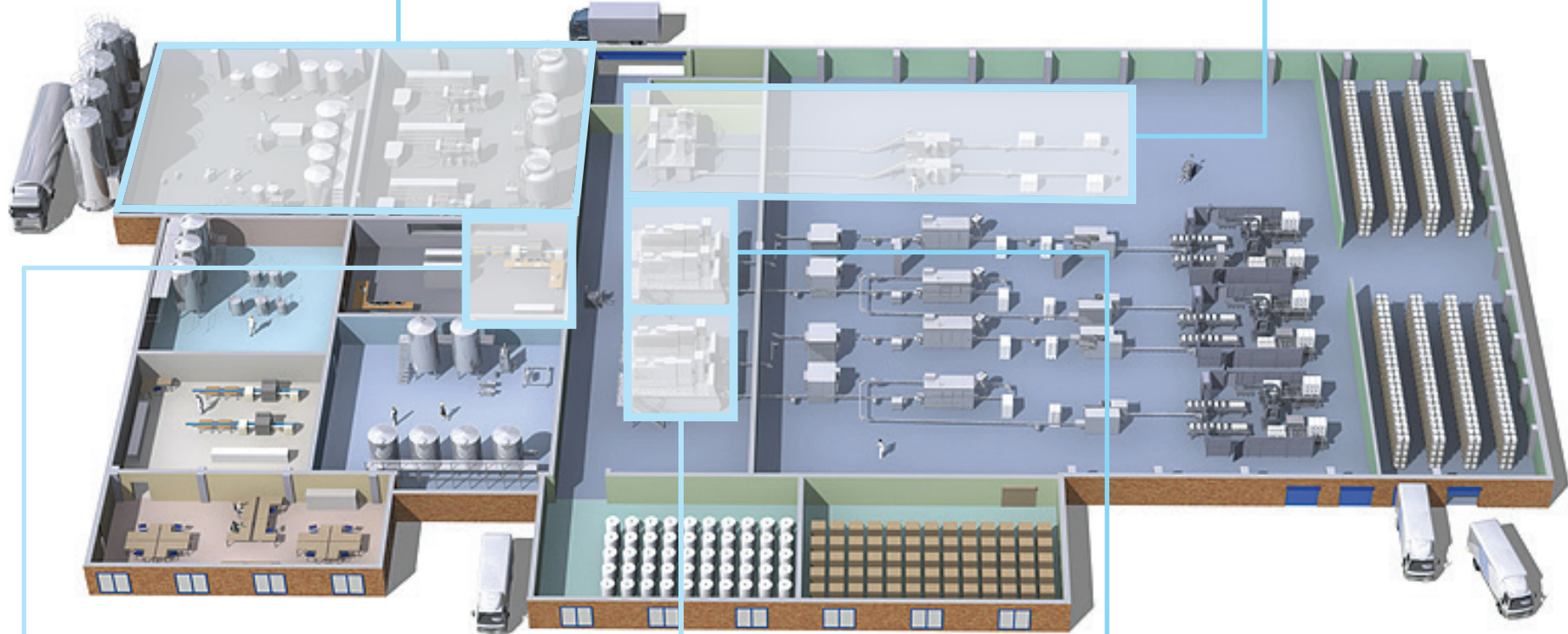

Plant Automation

- Tetra Pak® Plant Master:
 - Production Control
 - PI/MES/PLMS
- Tetra Pak IT/OT Infrastructure (Virtualisation)
- Tetra Pak® Plant Master Traceability Upgrades
- SCADA System & Report Generation
- Wonderware Intouch Upgrade
- MES Manufacturing Execution System

Packaging

- RK PAM/SAM
- RK FLEXBOX VI
- RK GE90-30

Packaging

- RK TPMC
- RK Rockwell L63 PLC



Tetra Pak® Plant Master Software Upgrades

UG Name	Tetra Pak Plant Master Software Upgrades – Production Control
System/Machine affected	Tetra Pak Plant Master Solutions & Non-Tetra Plant Master automation solutions
Value Category	Production functionality, Quality, Operational Efficiency & Cost
Implementation Time	Depends upon size of solution

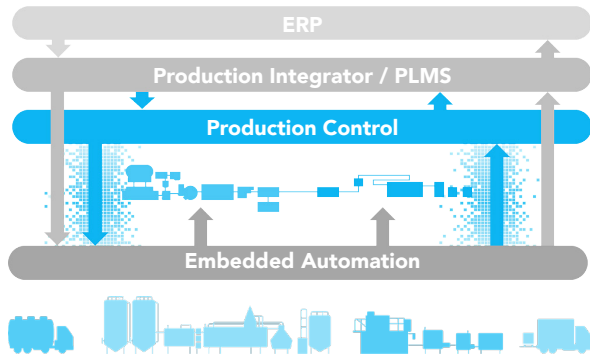

What does it do:

The TPPM PC comes with:

- Upgrade of controller software, such as PLC and HMI systems
- Unique configuration matching the process application and plant hardware
- Designed and delivered based on consistent and proven S88 & S95 standards
- Factory Acceptance Testing
- Installation, I/O checking & Commissioning

Benefits:

- Get total control for guaranteed food safety and consistent product quality
- Greatly simplify operation with one user interface and intuitive, task-based navigation
- Maximize OEE and cut operational cost by reducing downtime, waste and recalls
- Increase process stability and reliability by reducing risk of human error
- Base for future platform for advanced and rapid traceability information available at the click of a button



New Control System – Separator

UG Name	New Control System
System/Machine affected	PX614, PX714, PX518, PX618, PX718, PX818, PX918
Value Category	Operational Efficiency and Life Cycle Management
Implementation Time	5-7 days



What does it do:

The replacement is composed by:

- Siemens ET200S controller or AB CompactLogix L43
- Siemens TP700 Comfort panel or AB PanelView plus 700
- New electrical panel and electrical connection
- Update technical, operator and electrical documentation if applicable & available in electronic version
- Delivery and installation of the hardware and software
- Recommissioning
- Operator training

Benefits:

- Higher performance and responsiveness
- Improved process and parameter visibility
- Extended Life time with hardware and software supported by Tetra Pak
- Faster automation support via the standardized Global User Interface
- Ability to integrate new I4.0 technologies
- Improved machine monitoring

New Control System – Tetra Therm, Alsafe & ALCIP

UG Name	New Control Panel System
System/Machine affected	All Steriliser, Alsafe & ALCIP
Value Category	Operational Efficiency and Life Cycle Management
Implementation Time	10 days



What does it do:

The replacement is composed by:

- Latest solution on Rockwell / Siemens platform
- New electrical panel and electrical connection
- Update technical, operator and electrical documentation if applicable & available in electronic version
- Delivery and installation of the hardware and software
- Recommissioning
- Operator training

Benefits:

- Higher performance and responsiveness
- Advance automation system with higher life cycle
- Improved process and parameter visibility
- Extended Life time with hardware and software supported by Tetra Pak
- Faster automation support via the standardized Global User Interface
- Ability to integrate new I4.0 technologies
- Improved machine monitoring



SCADA & Report Generation

UG Name	SCADA & Report Generation
System/Machine affected	All
Value Category	Operational Efficiency
Implementation Time	Depends on number of equipments



What does it do:

This solution allows to monitor and control manufacturing processes by means of an interface capable of extracting information on components and processes, such as:

- Sensors
- PLCs
- Scales

This application stores all the information entering the system and automatically analyzes – in real time – the correct process operation, enabling comparison with previous production data in order to identify with possible improvements.

Benefits:

- Obtain information leading to better process traceability
- Storage of performance data in order to correct quality problems
- Creating a smart maintenance regime and decreasing downtime
- Making operator's jobs easier by having graphical statistics presented in real time
- Achieve a more connected operation and take the next step towards Industry 4.0



04 ICE CREAM

Ice cream may be one of the world's favourite desserts, but as manufacturers know only too well, the demand for novelty is relentless. Product innovation is essential, and it's not only a question of new flavours; the product has to look irresistible too. Regular variations in shape, dipping, toppings and wrapping all help attract attention. Explore ways with Upgrades to take performance to a whole new level.



Productivity & Efficiency

Control Upgrade
for Tetra Pak®
Continuous Freezer

Control System
Migration

Ice Cream Filler
Airless Chocolate Spray

Dynamic Pressure
Distributor

Tetra Pak®
Extrusion Wheel

Multi Dasher – Freezer



Food Safety & Quality

Dry Run Protection
for Freezer



New Requirement for your Line

New Product Upgrade
– Extrusion

New Product Upgrade
– Rotary Moulder

ICE CREAM UPGRADES PRODUCT PORTFOLIO

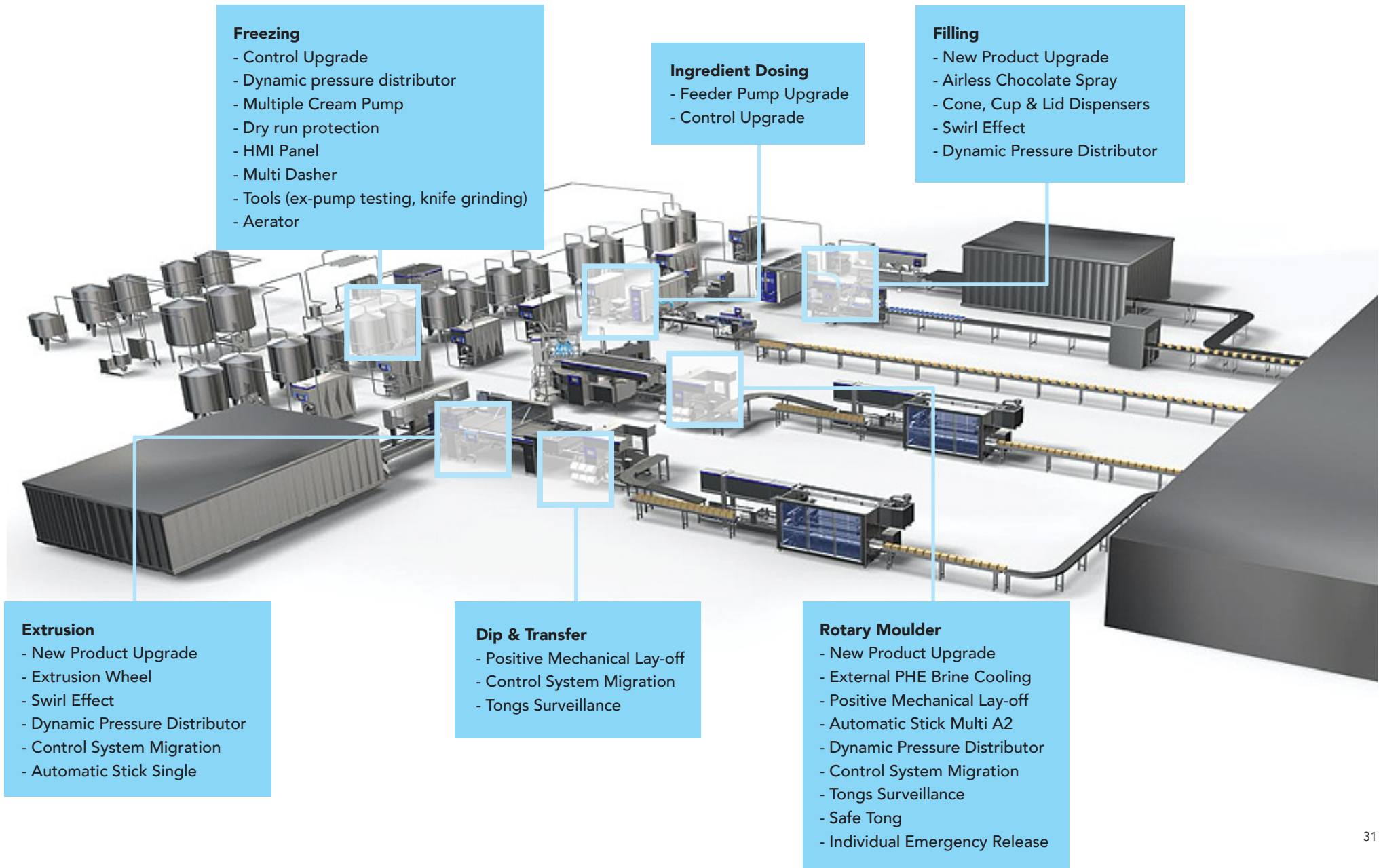

Control Upgrade for Tetra Pak® Continuous Freezer

UG Name	Control Upgrade for Tetra Pak® Continuous Freezer
System/Machine affected	Tetra Pak Continuous Freezers
Value Category	Operational Efficiency, Production Capability, Automation Life-Cycle Management, Environment
Implementation Time	5 days approx

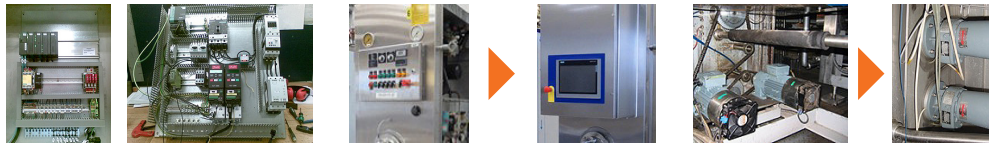

PLC and electrical components mounted on backplate

OP panel installed in new cabinet door

Optional motor and gear direct drive

What does it do:

- All necessary parts/units such as new sensors and control components are included in the upgrade kit
- Upgrade kits are designed based on the original configuration of the freezer
- Kits are delivered ready to build into the freezer
- The upgrade secures spare part supply availability and includes an extensive service maintenance program
- Active pump speed control and instant read-out of essential process parameters

Benefits:

- Higher output constancy, reducing production cost and ensuring constant quality ice cream
- Faster start-up reducing product loss and rework
- More user-friendly operation
- Reduced and secured maintenance cost
- Proven solution with >200 systems in operation
- Allows remote connectivity and support
- Enables I4.0 possibilities

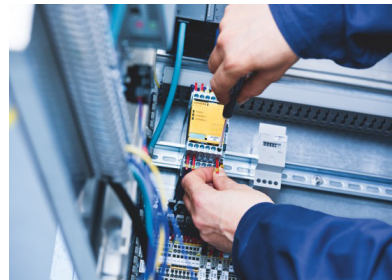

Control System Migration

UG Name	Control System Migration
System/Machine affected	Tetra Pak Extrusion Tunnel, Rotary Moulder, Wrapper and Dip & Transfer units
Value Category	Operational Efficiency, Production Capability, Automation Life-Cycle Management; Environment
Implementation Time	10 days approx



What does it do:

- Can include all necessary automation components to bring the system up to the latest generation
- Depending on the machine/line set-up, the scope will vary
- Complete technical documentation and documented quality check of the installation
- The upgrade utilizes either Siemens S7 platform or Rockwell CLX platform

Benefits:

- Full spare part supply secures minimal time of delivery and downtime
- Enables Improved Production Flexibility
 - Better compatibility for future upgrades and new modular design principles, making the production line more flexible regarding production of new ice cream products
- Facilitates Introduction of New Ice Cream Products
- Enables new production equipment, e.g. servo cutter in pre-programmed software
- Improves Product Quality
 - Full line integration provides:
 - Better diagnostics
 - Maximum consistency in production
 - Accurate correction of deviating production parameters
 - Recipe storage
- Allows remote connectivity and support
- Enables I4.0 possibilities

Ice Cream Filler Airless Chocolate Spray

UG Name	Tetra Pak® Airless Chocolate Spray
System/Machine affected	Tetra Pak® Ice cream filler A2/A3, CometC/ C2, Comet N, Fillmark, Cattani, Viking and 3rd party machines
Value Category	Operational Efficiency, Environment
Implementation Time	1-2 day per freezer

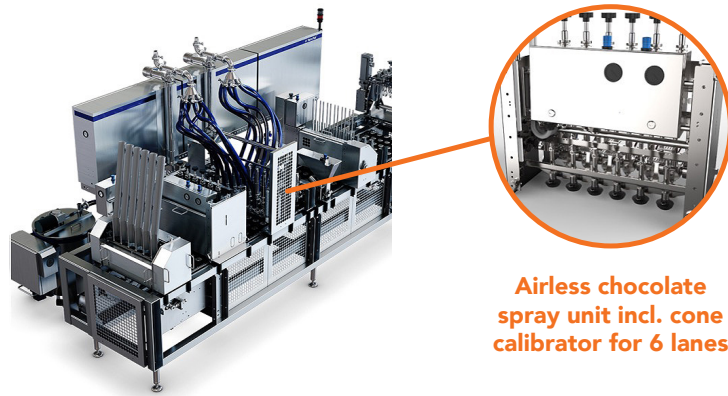

Airless chocolate spray unit incl. cone calibrator for 6 lanes

What does it do:

- Volumetric filling nozzles enable exact and desired amount of chocolate in each cone
- Chocolate circulation for maintaining chocolate temperature no nozzle blocking
- On the fly adjustments
- Hygienic design
- Low risk at integration with stand alone control system

Benefits:

- Accurate chocolate dispensing due to volumetric filling
- Reduced waste integrated cone calibrator incl. cone detection no cone no spray
- More uptime chocolate spray can be adjusted in operation



▶ *Based on Tetra Pak IC Filling Machine

Dynamic Pressure Distributor

UG Name	Pressure Distributor
System/Machine affected	Tetra Pak® Extrusion tunnels Tetra Pak® Ice Cream Filling machines Tetra Pak® Moulding machines (Inline & RM) 3rd Party Machines
Value Category	Operational Efficiency
Implementation Time	3-6 days



What does it do:

- Blender housing with multi blades for mixing inclusions and break flow, to secure uniform distribution to all outlet holes in bottom
- Customized bottom plate to actual flow for optimizing ice cream distribution to multiple lanes
- Distribution head with multi blade scraper to prevent blocking of outlet holes in case of inclusions in ice cream
- Hygienic design, CIP
- Separate control box

Benefits:

- Equal distribution, lower standard deviation in ice cream weight
- Proven solution reduce risk of failure and downtime
- Easy machine integration

Tetra Pak® Extrusion Wheel

UG Name	Tetra Pak® Extrusion Wheel
System/Machine affected	Tetra Pak Extrusion Line
Value Category	Production Capacity, Environment
Implementation Time	3-5 days



What does it do:

- Mould wheel for extruding ice cream with large inclusions in one to four lanes, on to an extrusion worktable (One lane production of one product size per extrusion wheel)
- Suitable for production of both stick and sandwich ice cream products with large inclusion including:
 - Servo motor drive synchronized with basic machine
 - Cleaning in place system
 - One test of unit in laboratory with customer inclusion and mix recipe before shipping

Benefits:

- High product quality
- Flexibility on ingredient size (up to 25mm)
- High yield and maintained extrusion capacity
- Great environmental and safety performance
- Low running cost
- Stick placing accuracy constant and exact
- No nitrogen cooling needed
- Small size and only needs electrical connection
- Less downtime with less frequent defrosting

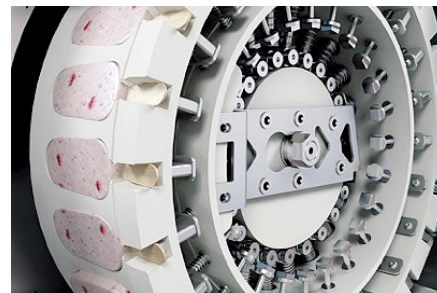

Multi Dasher – Freezer

UG Name	Multi Dasher – Freezer
System/Machine affected	Tetra Hoyer Frigus KF Continuous Freezer
Value Category	Operational Efficiency
Implementation Time	1-2 days

Old Design



New Design



What does it do:

- The Multi Dasher unit for Tetra Hoyer Frigus KF Continuous Freezer replaces the standard dasher.
- Generally suitable for all applications, especially advantageous for water ice, sherbet, low fat products and “all natural” recipes.
- The unit prevents ice build-up on the knives and dasher of your freezer, enabling longer intervals between required thawing and in most cases eliminates the need for thawing during production compared to the standard dasher.

Benefits:

- Increases freezer uptime
- Maximized production efficiency
- Recipe flexibility increased
- Optimized knife angle to the cylinder wall for improved performance

Dry Run Protection for Freezer

UG Name	Dry Run Protection
System/Machine affected	Control upgraded KF freezers for CF or F1 level (Freezers manufactured from 2004-2014)
Value Category	Food Safety and Operational Efficiency
Implementation Time	1 day per freezer

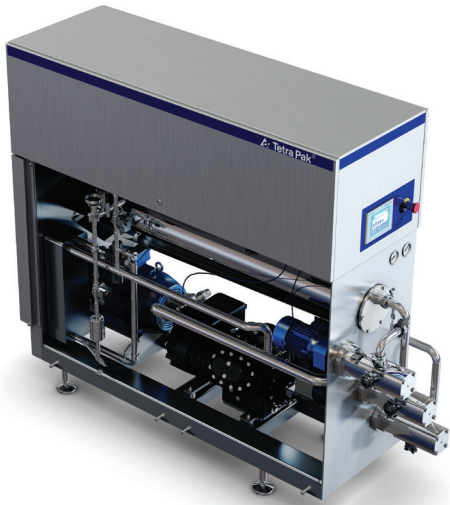

What does it do:

- A pressure transmitter will constantly monitor the inlet pressure to the mix pump combined with input measured on the mix flow meter
- In case the pressure and flow is too low the dasher and pumps are stopped
- Scope of supply
 - One inlet pressure transmitter
 - Electrical drawings
 - Software on memory card
 - Installation guide

Benefits:

- More uptime (reduce risk of production stop)
- Reduced maintenance cost
- Reduced risk of food contamination (ex. chrome from the cylinder peeling off)



New Product Upgrade – Extrusion

UG Name	New Product Upgrade
System/Machine affected	Tetra Pak Extrusion Line
Value Category	Operational Efficiency
Implementation Time	Depends on new product

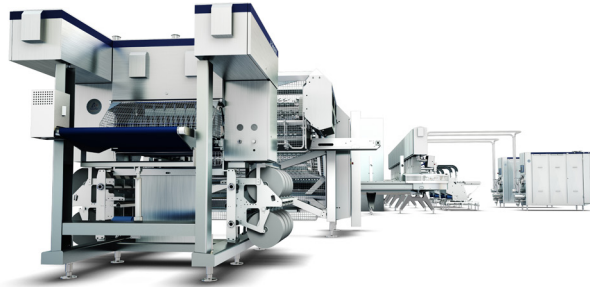

What does it do:

- New product upgrade for an existing extrusion line.
- Meeting and exceeding consumer expectations requires launch of innovative products.
- Various changes have to be made to the existing equipment depending on the demand of the new product. By this upgrade the time to introduce a new product in the market is short, which improves business.

Benefits:

- Increased Flexibility
- Improved Utilization

Ice Cream Sandwich



Candy Bar / Bite Size



Wafer Cups / Cones



Sticks



Cakes



New Product Upgrade – Rotary Moulder

UG Name	New Product Upgrade
System/Machine affected	Rotary Moulder
Value Category	Operational Efficiency
Implementation Time	Depends on new product



What does it do:

New stick moulded product upgrade for an existing rotary moulder line. Meeting and exceeding consumer expectations requires launch of innovative products.

Examples:

- **Combination Filler**
 - For small inclusions, up to 10mm (fruit pieces or similar)
 - Water ice, Ice cream & slush ice
 - One or two color filling
 - Less than 1% standard deviation between lanes
- **Dry Coating**
 - Equipment will create a “mist of nuts” (or similar dry material) in which the coated, but still “wet” product is dipped
 - Easy operation even in case of chocolate dip creating block-up – clean-out on the fly

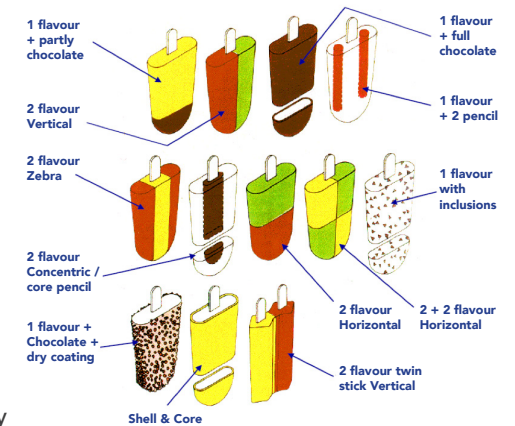

Benefits:

- Increased Flexibility
- Improved Utilization
- Short Payback Time



www.tetrapak.com

Please contact your sales representative for further discussion