

Tetra Pak® Membrane Lifting System

For easy loading of spiral-wound membranes



APPLICATION

The patented and CE certified membrane lifting system improves the working environment significantly for employees who install and replace membranes.

The system is easy to install on 8" membrane housings, using screws and bolts for fast installation on the membrane filtration system.

The system is designed to install and replace wet as well as dry membranes with a max. weight of 16 kg/ 35 pounds.

On the galleys, a profile rail supporting the crane trolley and the electrical cables is mounted inside the rail. After hooking the lightweight crane and membrane grab onto the trolley by hand, the lifting system is now ready to use. The membrane grab has an automatic open and close system that holds the membrane while it is lifted.

Tetra Pak's easy-to-use, patented Membrane Installation Tool supports the membranes and ensures that they are aligned correctly with seals: the anti-scoping device (ATD) or the energy-saving ATD (ESA).

HIGHLIGHTS

- CE certified for and easy to install on membrane filtration systems
- Substantial time savings, as membrane installation and replacements are carried out fast and easy in one operation
- Reduces physical work load on employees
- One lifting system can be used for more than one filtration system, being easy to demount and install again
- The system is easy to adapt to different makes of membrane housings
- The lifting system can be customized to all sizes of 8" membrane filtration systems, adding extended profile rails.

COMPONENT DETAILS

TETRA PAK® MEMBRANE LIFTING SYSTEM

Pos.	Item
1	Membrane Installation Tool (MIT), order no. 1754000-0894
2	6 meter profile rail (can be extended)
3	Welding support for profile rail
4	Trolley for chain telfer
5	Telfer with remote control

Pos.	Item
6	Membrane lifting grab
7	End stop for profile rail
8	Frame support 8" membrane housing
9	8" membrane housing
10	Sign: Max load 35 kg / 77 pounds

INSTALLATION

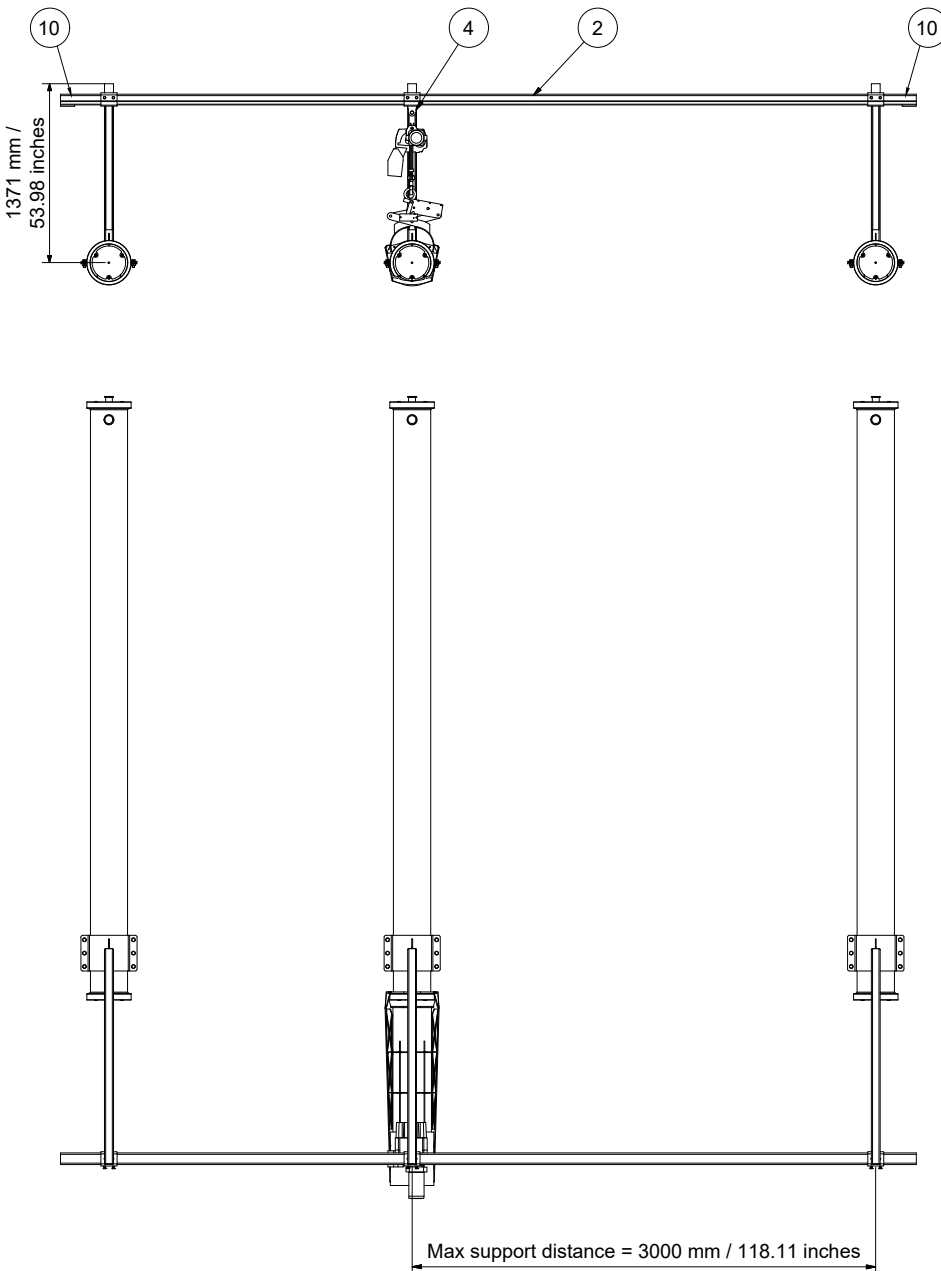

INSTALLATION

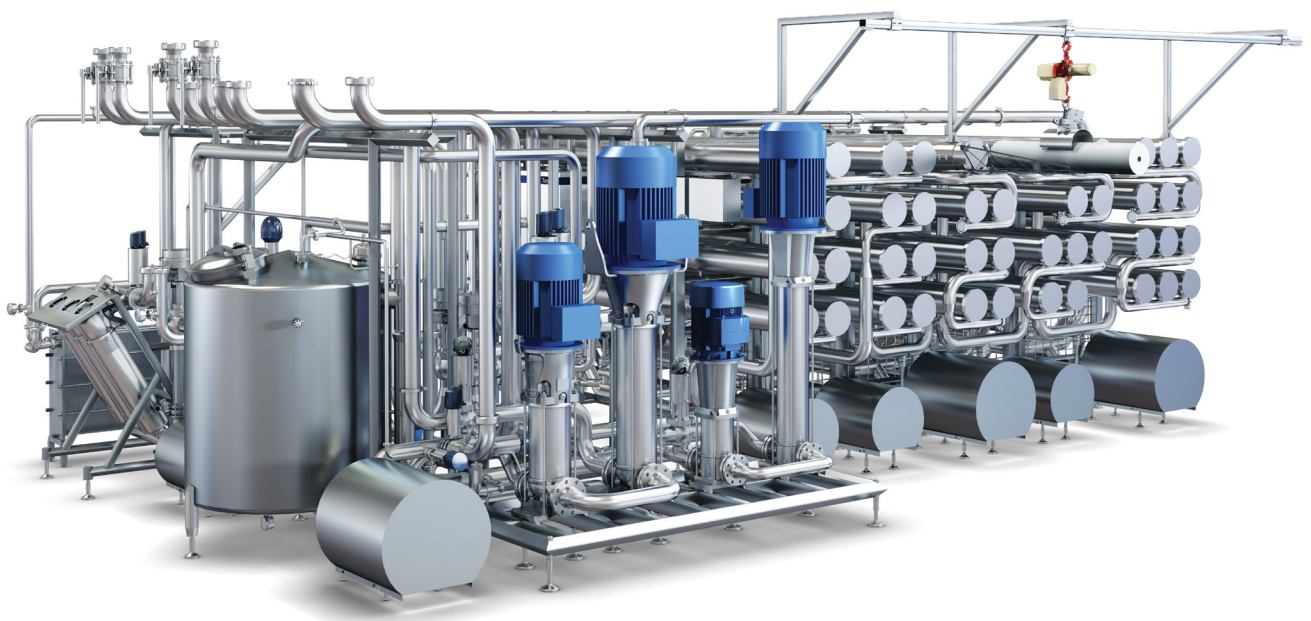
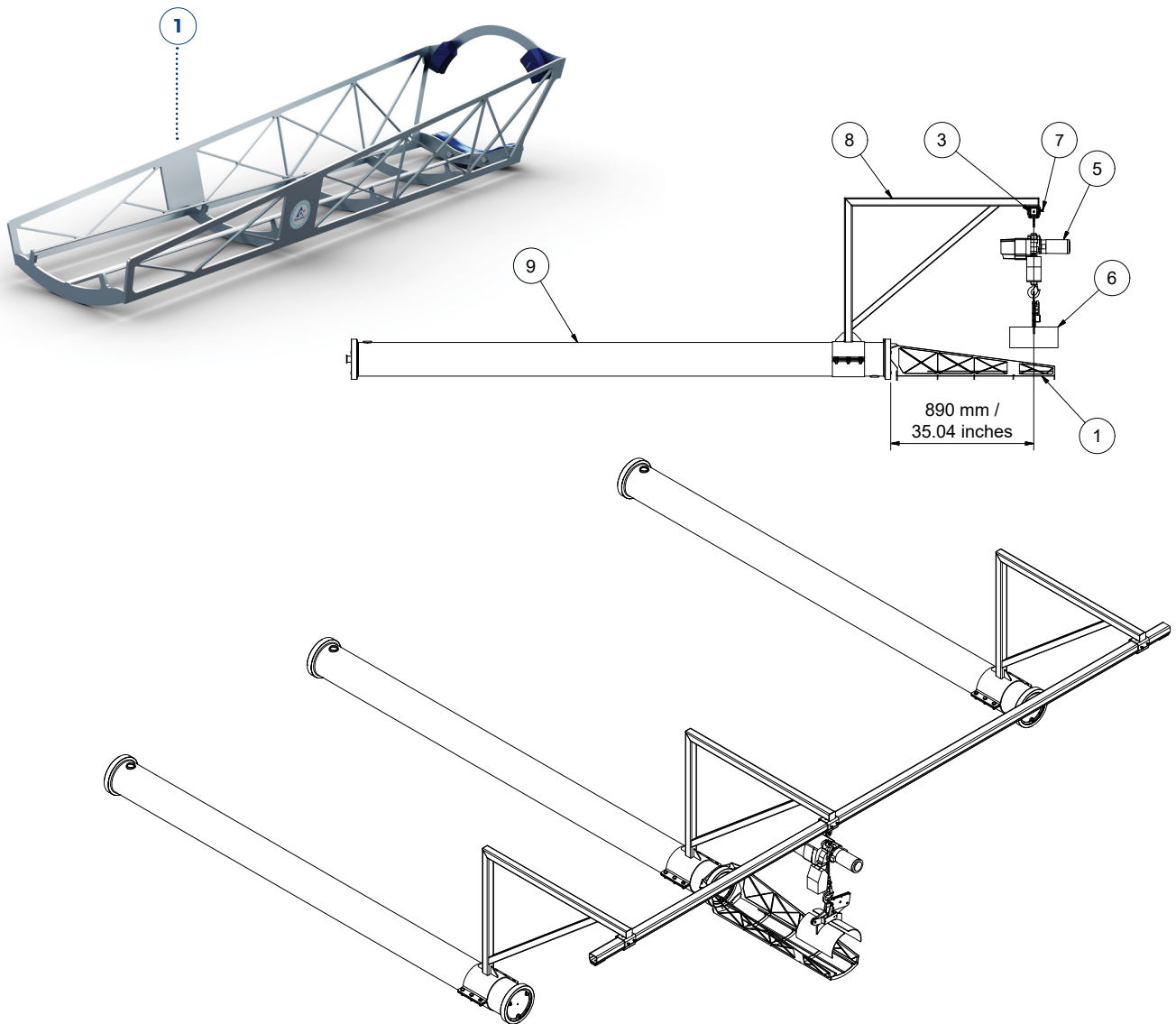

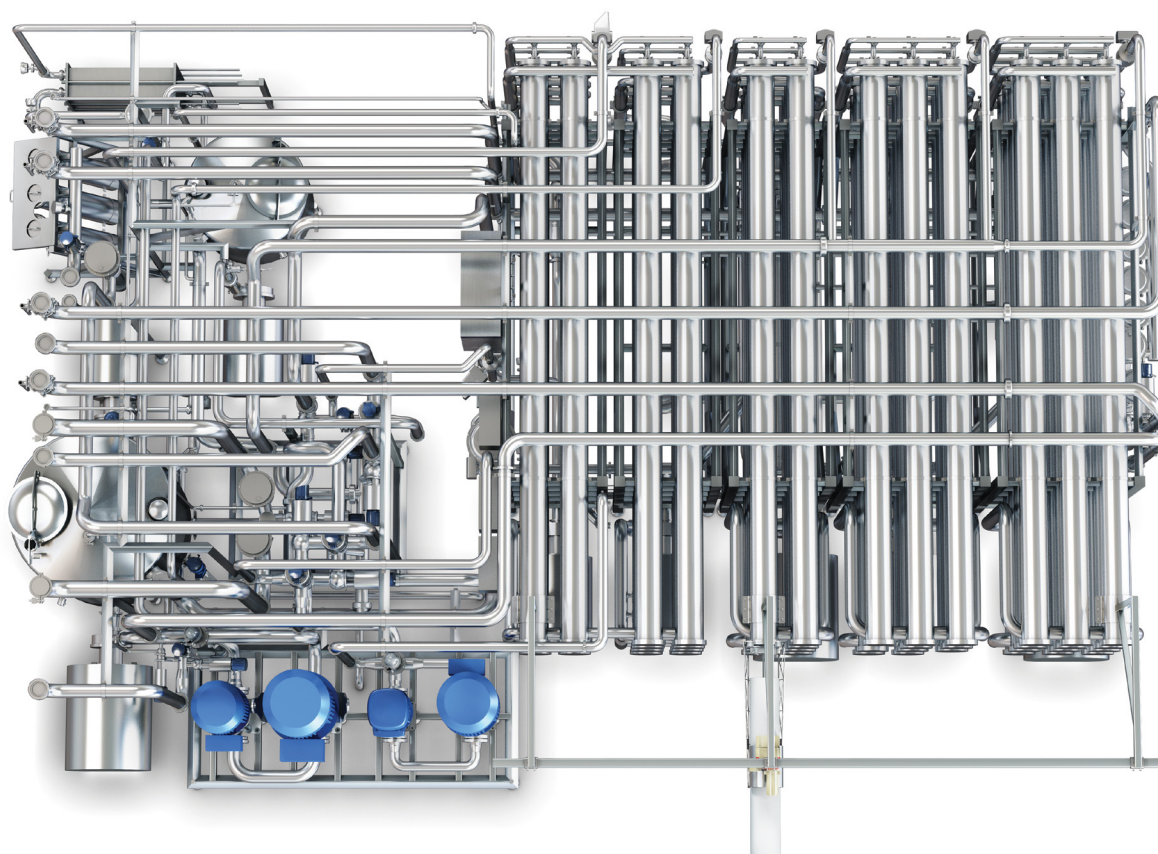
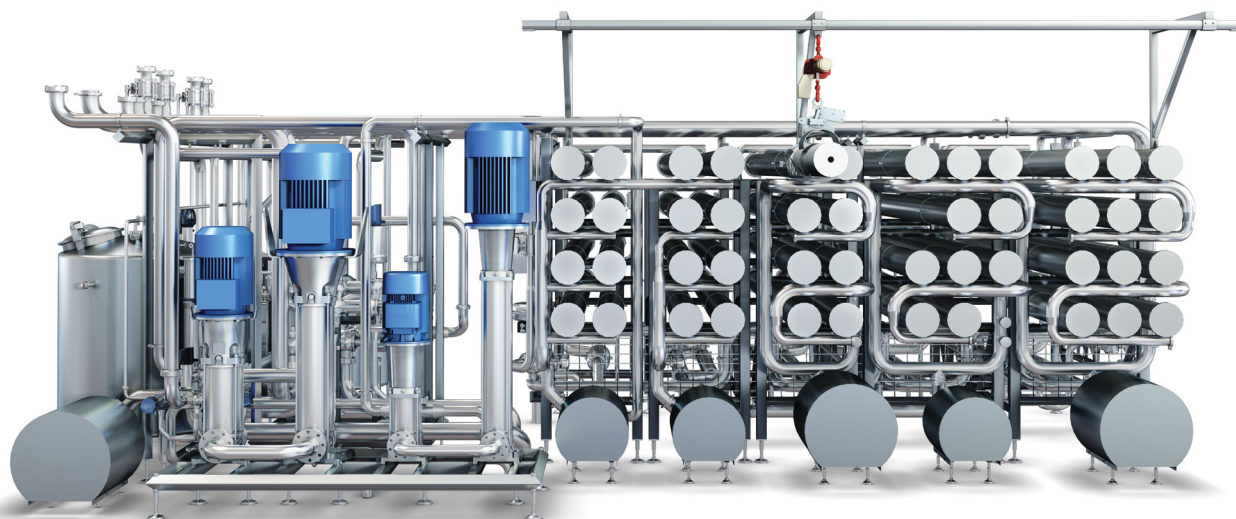

Tetra Pak

Filtration Solutions

filtration.info@tetrapak.com

www.tetrapak.com/membrane-filtration

Bergsøesvej 17	12255 Ensign Ave North
8600 Silkeborg	Champlin, Minnesota 55316
Denmark	U.S.A.
+45 8720 0840	+1 763 421-2721

Tetra Pak,  and PROTECTS WHAT'S GOOD are trademarks belonging to the Tetra Pak Group. www.tetrapak.com

 **Tetra Pak**[®]