



Powder Handling

Tetra Pak portfolio

High-performance powder handling solutions

Our solutions secure food safety with the highest hygiene and enable fast cleaning and low downtime. The reliable and robust design requires minimal maintenance and meets all demands for easy and safe operation.

Our expertise will guarantee full support for directives and regulations compliance to give you perfect control on dust emissions at any step of the process.

We offer optimised solutions for powder handling technology, but also master expertise in all powder processes such as gassing, cooling, packing, dilution, and IBC handling.

We cover the full spectrum for powder handling requirements in the food industry.



From simple ingredients to specialised powders, we have an extensive portfolio of powder handling equipment. Our expertise extends from handling powders in discharging and conveying operations, dosing, and dry mixing solutions, all the way down to powder packing at the end of the line. We cover the full spectrum for powder handling requirements in the food industry.

Wide application range

A powder handling solution can be used to control any type of powder either as a raw material such as sugar, milk powder, salt, flour, or as a finished product like infant formula, instant drinks, or dry broth.

Our offering

Our process starts with your product receiving station where you will use our dust-free tipping stations adapted for any kind of bag or big bags. The powder is cleaned to remove foreign bodies using sifters and magnet traps. We have a wide range of storage tanks and silos that includes explosion protection and extraction devices to offer a safe and easy storage capacity.

Powder can be transferred through pneumatic conveyors to any location in your factory. Tetra Pak has expertise in all types of pneumatic conveying technologies, including vacuum or pressure types. We can help you select the most suitable process, either in the dense phase or lean phase, to guarantee the most efficient transfer of the product.

We will prepare the final product recipe by dosing your different powder with the specified accuracy. The product dosing is perfectly controlled through our automation system and can work in batch mode or in-line continuous mode.

And our best-in-class dry mixing technology offers you the best combination between speed, homogeneity and powder breakage rate.

Environmental advantages

With expert knowledge to build line solutions, we secure food safety with the highest hygiene and enable fast cleaning and low downtime. The reliable and robust design requires minimal maintenance and meets your needs for easy and safe operation.

Benefit from our experience and expertise

We offer a complete range of proven equipment for powder handling installations. All our equipment can be delivered with ATEX certification. Based on our experience in full engineering, we have designed a wide range of equipment to meet your quality requirements. We provide this range as components that you can easily integrate into the installation.

An extensive portfolio

Benefit from our powder handling experience and expertise: we've launched three ranges for equipment and solutions, called Essential, Advanced and Premium, to make sure all our products & solutions fit the needs of the entire powder market.

Design, hygienic level and features are different concepts related to our portfolio to deliver according to your expectations.

We are therefore able to produce a wide variety of products, introduce new products or modify old products quickly and respond to your needs for growth.

Full support and service

With the long-term support of our Technical Sales & Service team, you can benefit from our experience and technical support, long after the start-up of your production line, both during the warranty period and throughout the life of the plant.

Validate the future production line

Our Product Development Centre (PDC) of in France offers a way to validate your future production line. In the associated pilot plant and laboratory, we encourage you to submit your products and requirements to achieve a safe industrial solution. Our team of engineers will work closely with you for optimum development.

Product portfolio

Tetra Pak Powder Handling

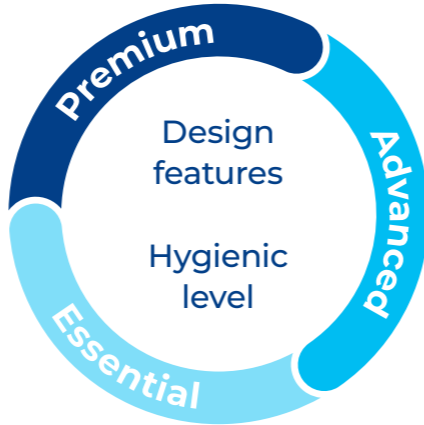
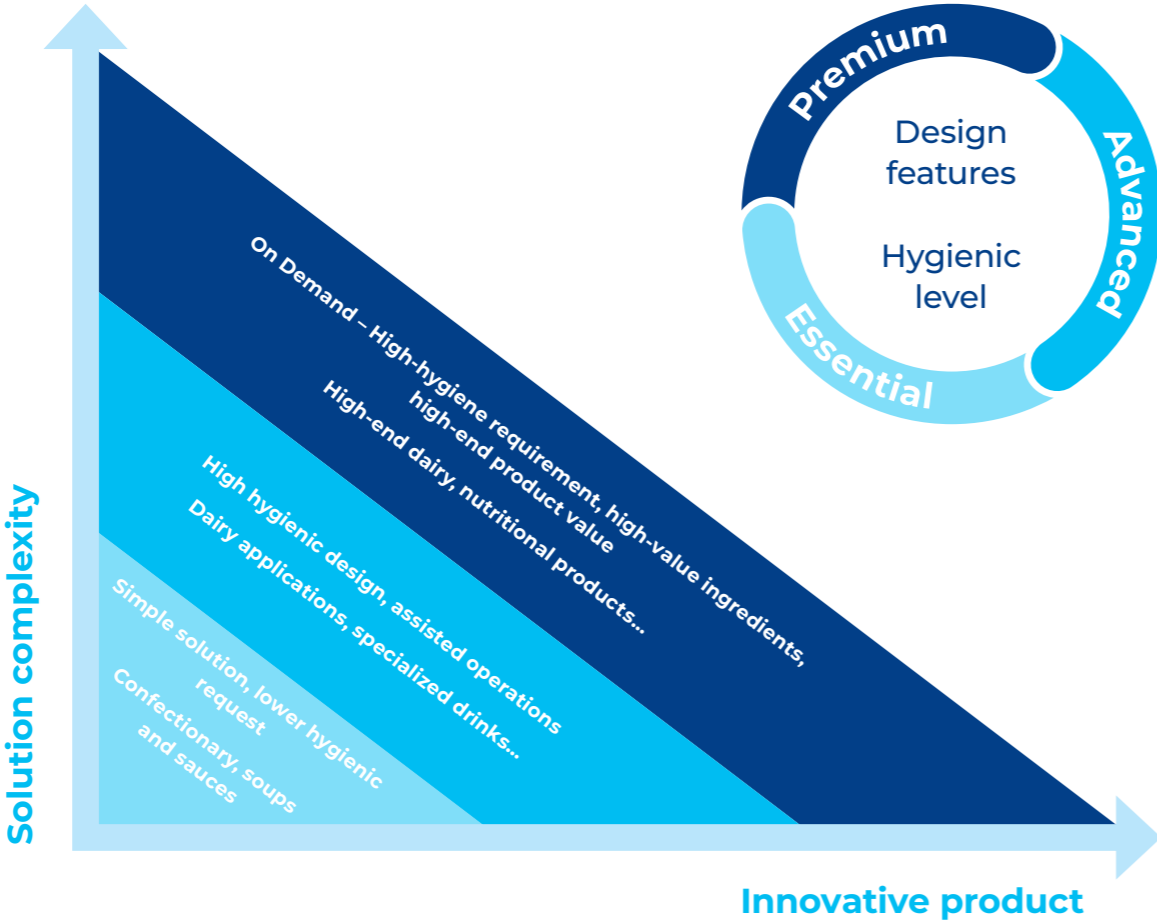

	Essential	Advanced	Premium
Tipping & discharging	●	●	●
Dosing & weighing	●	●	●
Screening & sifting	●	●	●
Mixing & blending	●	●	●
Convey & transfer	●	●	●
Filtration & separation	●	●	●
Packing & handling	●	●	●

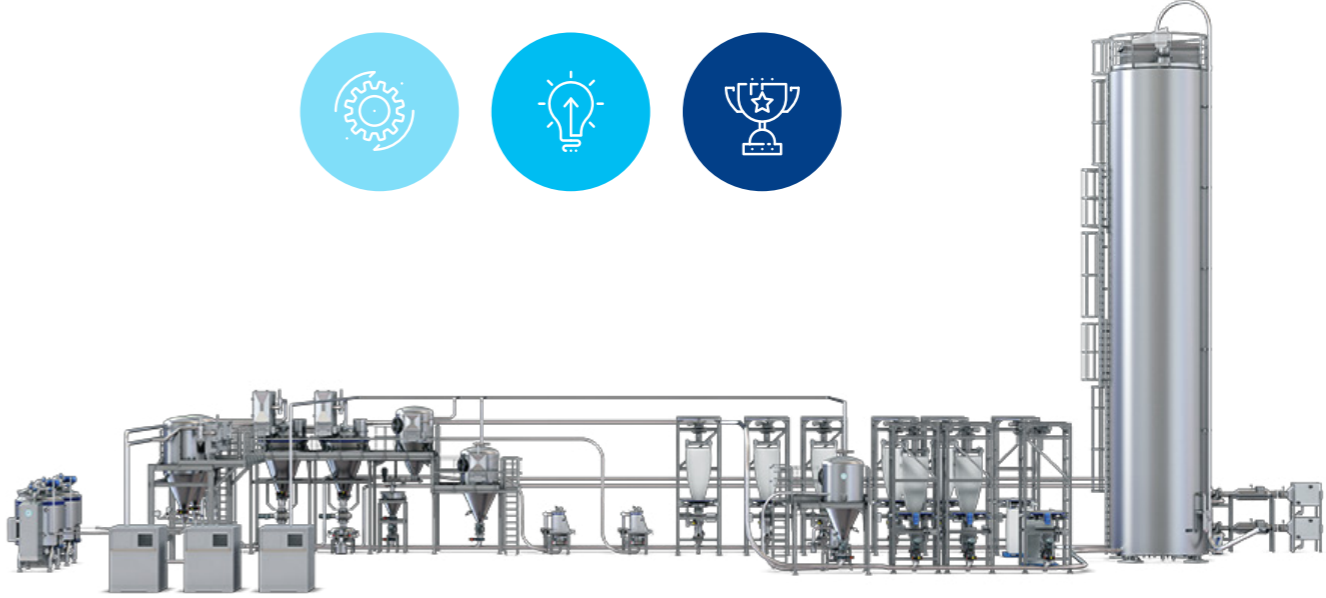

Application map

POWDER TO LIQUID

	Tipping & discharging	Convey & transfer	Filtration & separation	Dosing & weighing	Mixing & blending	Screening & sifting	Packing & handling
Dairy	●	●	●	●		●	
Yoghurt & fermented	●	●	●	●		●	
Infant formulas	●	●	●	●		●	
Flavoured & concentrated milk	●	●	●	●		●	
Ice cream	●	●	●	●		●	
Soup, sauces & desserts	●	●	●	●		●	
Beverages	●	●	●	●		●	
Recombined milk	●	●	●	●		●	

LIQUID TO POWDER

	Tipping & discharging	Convey & transfer	Filtration & separation	Dosing & weighing	Mixing & blending	Screening & sifting	Packing & handling
Milk powders		●	●			●	●
Whey powders		●	●			●	●
Lactose		●	●			●	●
Permeate		●	●			●	●
Milk protein concentrate		●	●			●	●
Starches		●	●			●	●
Plant based powders		●	●			●	●

POWDER TO POWDER

	Tipping & discharging	Convey & transfer	Filtration & separation	Dosing & weighing	Mixing & blending	Screening & sifting	Packing & handling
Nutritionals (infant & adults)	●	●	●	●	●	●	●
Bakery, biscuits & cereals	●	●	●	●		●	
Powdered drinks	●	●	●	●	●	●	
Confectionary	●	●	●	●		●	
Instant meals, soups & cooking sauces	●	●	●	●	●	●	
Sport & weight management	●	●	●	●	●	●	
Beverages	●	●	●	●	●	●	
Baby cereals & dry meals	●	●	●	●	●	●	

KEY

Tipping & discharging: Bag and bulk discharging

Convey & transfer: Pneumatic transfer, screw conveyors, vibrating conveyors

Filtration & separation: Reverse air jet filters

Dosing & weighing: Powder feeders

Mixing & blending: Batch mixers

Screening & sifting: Sifter, magnet, de-lumper

Packing & handling: Bulk bag filler



Tipping & discharging

Extensive range to handle different types of raw material

Our wide range tipping and discharging equipment is designed to handle raw materials under different formats and at different capacities and rates. Some are simpler and manually operated, while others have assisted or automatic operations. They are designed to receive ingredients in any kind of packaging, from bags to big-bags, trucks and rail cars.

Application examples



Dairy



Beverages



Ice cream



Prepared food



Dairy ingredients



Whey



Plant-based



Nutritionals



Portfolio range

- Essential
- Advanced
- Premium

Tetra Pak®
Big Bag Tipping
Unit VB004



Tetra Pak®
Bag Tipping
Unit SA VS800

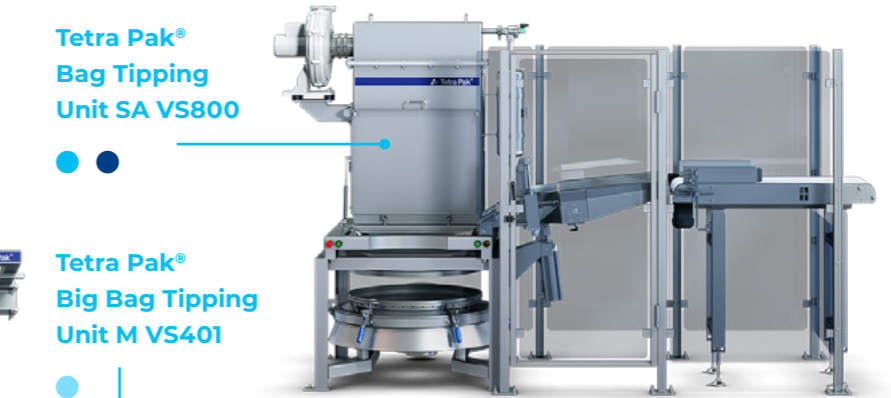

Tetra Pak®
Big Bag Tipping
Unit M VS401



Tetra Pak®
Big Bag Tipping
Unit VB006



Tetra Pak®
Big Bag Tipping
Unit CS VS600



Convey and transfer

Moving powder from point A to point B

We have a wide range of equipment for conveying and transferring that will help you move powder from point A to point B. It can be done mechanically, by vibration or by the means of air under pressure or vacuum.

Our screw conveyors are specifically designed to convey and/or dose any type of granulated or powder components over short distances. Pneumatic conveying moves powders from point A to point B using controlled air flow within piping routes. The jolting movement of the vibrating conveyor causes the product to lift and move horizontally to the end of the trough.

Application examples



Dairy



Beverages



Ice cream



Prepared food



Dairy ingredients



Whey



Plant-based



Nutritionals



Portfolio range

- Essential
- Advanced
- Premium

Tetra Pak® Screw Conveyor HD ET

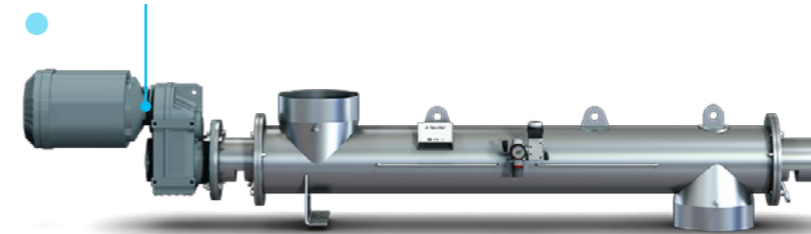

Tetra Pak® Screw Conveyor ET

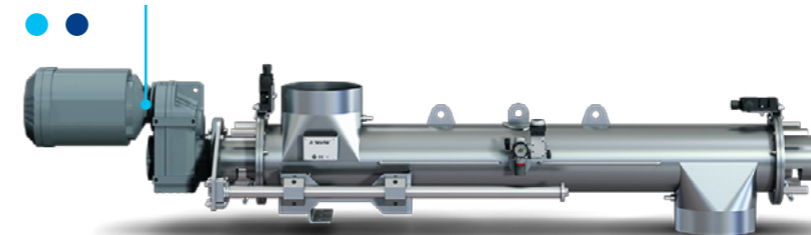

Tetra Pak® Vibrating Conveyor EV

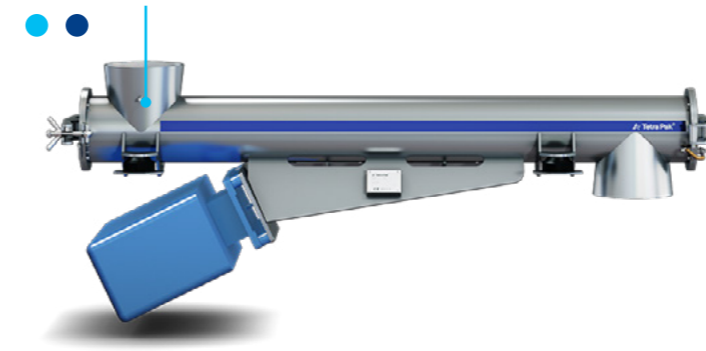

Tetra Pak® Pneumatic Conveyor VDP FD



Tetra Pak® Pneumatic Conveyor PDP FO



Filtration and separation









Dust filtration and volumetric air exchange

We offer a wide range of equipment that will enable dust free operations for your powder applications. Using powder filters will separate and recycle the powder from the air flow, either in volumetric exchange or in pneumatic conveying applications.



The filters are suitable for the food industry with high hygienic requirements for powder products such as infant formulas, dairy products, nutritional products and food supplements.



Application examples

-  Dairy
-  Beverages
-  Ice cream
-  Prepared food
-  Dairy ingredients
-  Whey
-  Plant-based
-  Nutritional

Portfolio range

-  Essential
-  Advanced
-  Premium

Tetra Pak®
Dust Filter FL001



Tetra Pak®
Dust Filter FL002



Tetra Pak®
Dust Filter FL200



Dosing and weighing

Optimal control of amount and flow

The objective of dosing and weighing is to control the flow and dose out the powder in consistently correct amount – according to your needs or the specific requirements of different products (recipe management).

Dosing powder is often at the core of solids processing, and any deviation can lead to production losses. The final product can be off specification if an ingredient was dosed improperly, leading to rework or even product destruction.



Application examples



Dairy



Beverages



Ice cream



Prepared food



Dairy ingredients



Whey



Plant-based



Nutritional

Portfolio range

- Essential
- Advanced
- Premium

Tetra Pak®
Powder Feeder
DN061

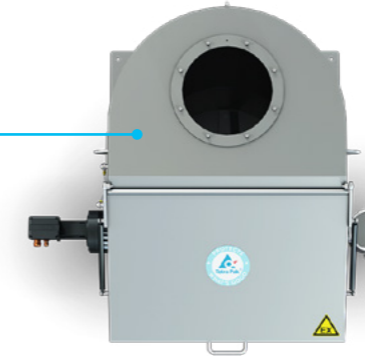

Tetra Pak® Screw Conveyor ET

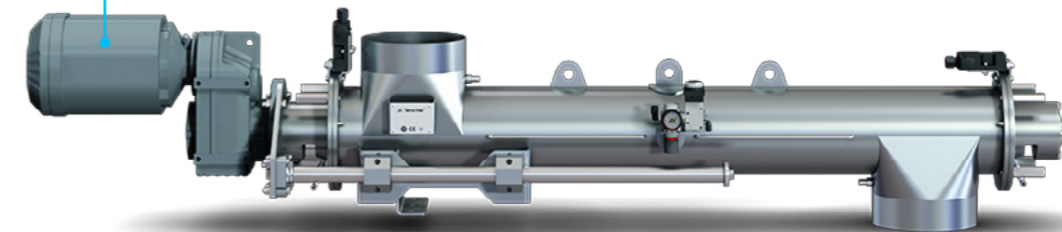

Mixing and blending

Creating a good blend

Mixing is a combination of different powders together in a mixing chamber, to create a homogeneous product within strict constraints. Our range of equipment uses three mixing principles: diffusion, convection, and shearing.

There are many categories for mixing handling, including nutritional powders, infant formula, prepared food powders, beverage powders and flour- and sugar-based ingredient powders.

Application examples



Dairy



Beverages



Ice cream



Prepared food



Dairy ingredients



Whey



Plant-based



Nutritionals



Portfolio range

- Essential
- Advanced
- Premium

Tetra Pak®
Vertical
Homogenizer
TV



Tetra Pak®
Powder Mixer
B3500

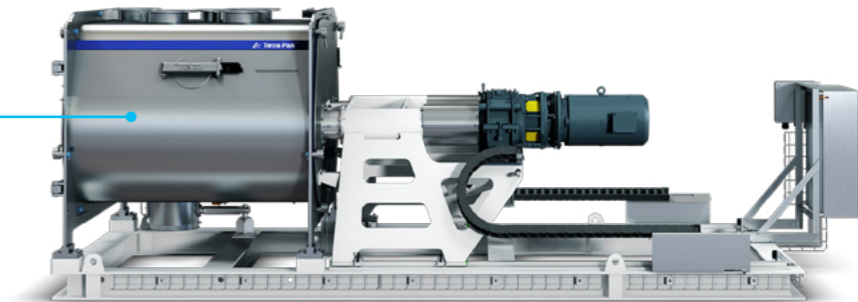

Packing and handling

For the ultimate protection

There are many powder packing solutions. Whether it's main packages intended for business-to-business operations, or retail powder from a few kilograms in small bags, pouches, jars, plastic containers, to grams in sachets.

Powders are less fragile than liquids but still require proper packing to avoid contamination or foreign bodies, for ease of transport, for storage, to improve shelf life, and protect from degradation.

Application examples



Dairy



Beverages



Ice cream



Prepared food



Dairy ingredients



Whey



Plant-based



Nutritionals

Portfolio range

- Essential
- Advanced
- Premium



● Tetra Pak®
Big Bag Filling Unit DB010

● Tetra Pak®
Big Bag Filling Unit S DB006

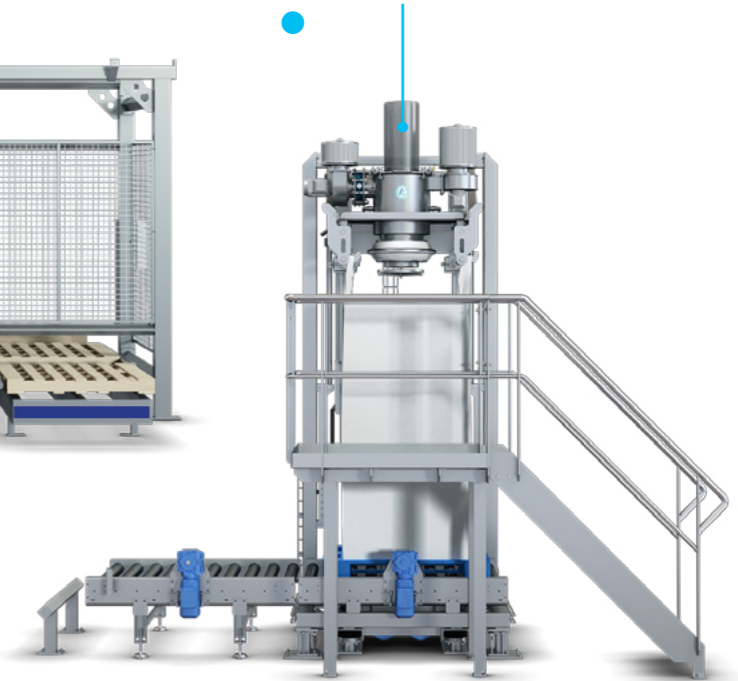

Screening and sifting

Securing efficiency and food safety

Our wide range of safety equipment covers sifting and cleaning processes, including metal detection and magnetic separation: from sifting, magnets, lump breakers to grinders.

The sifter is specifically designed to safely remove foreign matter from any powder. The lump breaker is used for breaking up friable lumps and agglomerates that can be formed during storage of dry powders and granulates.

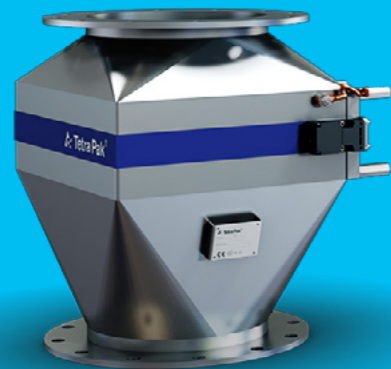

Application examples



Dairy



Beverages



Ice cream



Prepared food



Dairy ingredients



Whey



Plant-based



Nutritionals

Portfolio range

- Essential
- Advanced
- Premium

Tetra Pak®
Sifter TR201

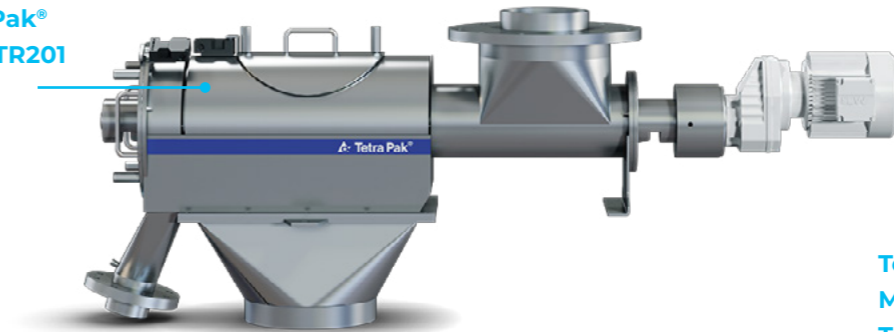

Tetra Pak®
Lump Breaker TD041



Tetra Pak®
Magnetic Separator TM400



Addressing your powder handling challenges

Benefits

- Minimised downtime
- No cross contamination
- Dosing & mixing efficiency
- Powder behaviour & characteristics expertise
- Regulatory compliance
- Traceability
- Explosion protection
- Consistent product quality
- Hygienic design
- Performance guarantees
- Recipe handling & PTS





Reliable partner with end-to-end solutions to meet your needs

Eco-friendly equipment manufacturing

We offer global delivering, through local resources of regional sourcing on all continents. Regional manufacturing covers main world regions in Asia, Europe and America.

Global products, local support

With over 50 years of know-how in powder, and an extensive network of global and local expertise, we can provide you with sound technical knowledge, guidance and life cycle support, anytime, and anywhere.



