



Drive for Tetra Damrow™ Double-O Vat

Upgrade Services



Application

Double-O cheese vats delivered up to 1993 are supplied with drives that are no longer available or supported by the supplier.

Since drive parts are no longer available, in the event of a breakdown, the entire drive will need to be replaced.

This can result in down time that could have been avoided.

By proactively upgrading the drive, this risk is not a factor any longer.

This upgrade can be applied to almost all Double-O flat bottom cheese vats within the size of 6.000 to 16.000 litres, delivered from 1981 to 1993.

Since 1993, all the Double-O cheese vats have been delivered with the type of drive described in this upgrade.

Benefits

- Higher reliability
- Extended lifetime of the equipment
- Reduced maintenance
- Increased motor power

Operating principle

The functionality of the drive upgrade is the same as the original drive, but improved. The drive upgrade reduces the need for maintenance because the shaft between the two gear boxes has no bearings.



Scope of supply

1. Main gear box with motor
2. Secondary gear box
3. Flange for cardan shaft
4. Cardan shaft
5. Flange for gear box MVF 150
6. Counter wheel
7. Nut M16
8. Pointed screw M8 x 10
9. Shaft seals

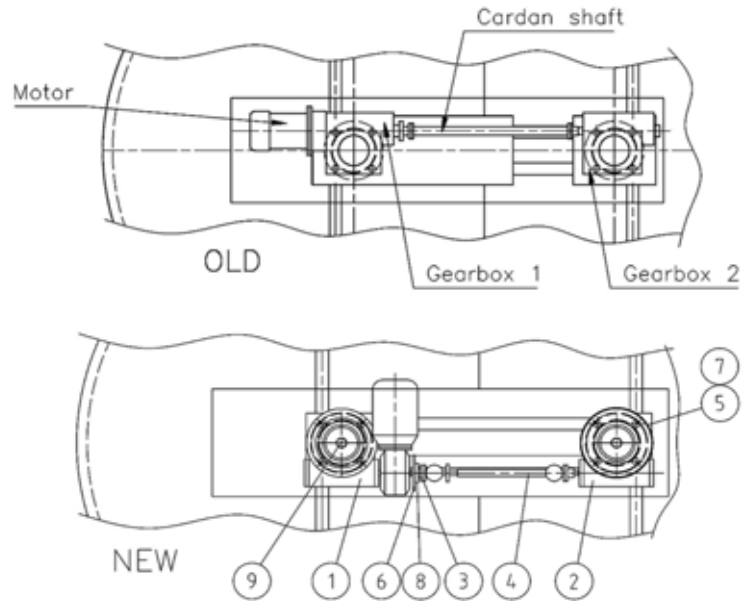

Technical Data

Motor 3 kW (3 x 400 V, 50 Hz).

Delivery time and installation procedure

The delivery time for up to two upgrades at a time is approximately four weeks. For quantities larger than two upgrades, the delivery time is up to 12 weeks. Estimated installation time is approximately 20 man hours in total for two fitters per upgrade.

Prior to ordering

This upgrade requires a frequency converter. Please check if the existing drive already has a frequency converter.

Please note that the frequency converter is not included in the scope of supply. A separate offer can be submitted on request.

The upgrade may require a modification in the automation software with respect to the stopping procedure and the frequency converter (subject to separate offer).

It is necessary to modify the motor cover because the drive configuration has changed. A small opening in the motor cover has to be made.

We recommend changing the shaft seals when the gear boxes are dismantled, regardless of the last time changed. The existing shaft key can normally be re-used.

Information required

Please submit as much as possible of the below required information.

- Machine number
- Size of the vat
- Original place of delivery
- Type and model of frequency converter (if present)

Contact

If you are unsure whether the upgrade is suitable for your equipment or if you need further information, please contact your local Tetra Pak representative.

The Tetra Damrow Double-O Vat is just one item in our portfolio of cheese making equipment incorporating the latest engineering standards and cheese making technology.

Our sales and engineering staff will work closely with you to design the optimum solution to meet all of your needs. Tetra Pak Cheese and Powder Systems offers complete in-house design, engineering, fabrication, installation and commissioning.