



Tetra Pak® CIP unit P

Smart CIP safety



Application

Tetra Pak® CIP unit P is an advanced automatic cleaning-in-place system used for cleaning process equipment such as filling machines, pasteurisers, sanitary pipes, tanks, aseptic tanks, plate heat exchangers etc.

The cleaning is fully adjustable to meet the demands of the cleaning object, i.e. times, concentration, temperature and flow. The capacity alternatives are 6 000-25 000 l/h and 10 000-50 000 l/h, which is normally enough for cleaning \varnothing 76 mm and \varnothing 101 mm sanitary pipes.

Tetra Pak CIP unit P is a platform-based unit that provides a wide range of flexible solutions with capacities and options for every customer/ market. Key benefits are food safety, production economy and flexibility. All units are prepared for easy integration with

Tetra PlantMaster™ or other supervisory systems. All units are pre-tested and prepared for easy installation.

Tetra Pak CIP unit P is suitable for cleaning of equipment for all food applications (dairy, beverage, carbonated soft drink, cheese, prepared food, brewery etc).

Working principle

The Tetra Pak CIP unit P unit consists of 1-4 pressure lines, all individually pre-assembled and frame-mounted. Each pressure line includes a pressure pump, circulation tank, tubular heat exchanger, process valves, sensors and all necessary internal piping and wiring. It can be connected to up to 32 CIP circuits, for which individual parameters (circuit volume etc.) can be set. The Tetra Pak CIP unit P is delivered with 14 pre-set CIP recipes. It is also possible to create customized CIP recipes which are, for customer safety, validated before use.

By applying the individual parameters of a CIP circuit to a certain CIP recipe, an optimized cleaning can be performed for that circuit. The Tetra Pak CIP unit P unit automatically controls the cleaning time, detergent temperature, flow and concentration. The control of detergent concentration and sorting of liquids in the Tetra Pak CIP unit P is done using a conductivity meter.

Tetra Pak® CIP unit P

Preparation of detergent

Preparation is started manually or automatically at a specific time or after a pre-set number of cleaning cycles.

Basic unit

The Tetra Pak® CIP unit P is compact, pre-assembled and frame-mounted. All modules are factory tested with water before delivery.

Main Components

- Frequency-controlled centrifugal pump
- Flow transmitter and flow switch
- Circulation tank with level transmitters
- Tubular heat exchanger
- Conductivity transmitters
- Temperature transmitters
- Automatic control and shut-off valve for steam
- Automatic shut-off valve for water
- Automatic sanitary valves for diversion and shut-off

Control panels

Tetra Pak CIP unit P is controlled by an Allen Bradley ControlLogix or Siemens PLC.

This is fitted in a cabinet located on pressure line A.

Layout

A motor control cabinet is also situated on pressure line A but can easily be moved away from the module. Remaining pressure lines are equipped with one line panel each.

Technical data

Capacity

- 6 000 - 25 000 l/h
- 10 000 - 50 000 l/h
- Outlet pressure, max 300 kPa (3 bar)

Consumption data per cleaning line

Electric power	
6-17 kW depending on selection	400 V, 50 Hz

Required water supply at 300 kPa (3 bar)	
6 000 - 25 000 l/h	25 000 l/h
10 000 - 50 000 l/h	50 000 l/h

Steam at 300 kPa (3 bar)	
25 000 l/h	max 970 kg/h, 240 kg/h nominal load
50 000 l/h	max 1 940 kg/h, 490 kg/h nominal load

Compressed air	
Steam regulating valve	150 NI/h at 600 kPa (6 bar)
Control panel	180 NI/h at 600 kPa (6 bar)

Measurements

LC Module 25 000 l/h	3 000* mm
HC Module 50 000 l/h	3 225* mm

* Additional free space required for service and maintenance above the equipment: 1 000mm.

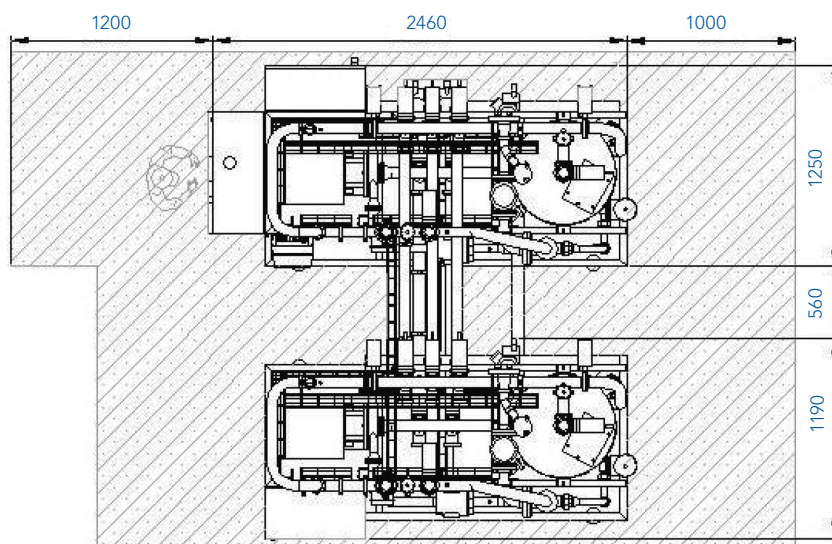

We reserve the rights to introduce design modifications without prior notice. Tetra Pak, PROTECTS WHAT'S GOOD and Tetra PlantMaster are trademarks belonging to the Tetra Pak Group.

www.tetrapak.com

 Tetra Pak®